

Specification

Electrical rating	10~100mA, 12~24VDC	40T85
Electrical Life	10~100mA, 12~24VDC	250,000 cycles
Mechanical Life	500,000 cycles	
Contact Resistance:	50mΩ Max. (initial)	
Operating Force:	200gf Max	
Insulation Resistance	100 MΩ Min.	
Dielectric Strength	500VAC for 60±5 sec	

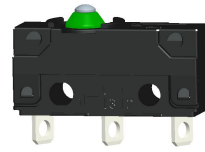

IP Protection

Series	Actuation Side	Terminal Side	OF	OP
S21	IP 67	IP 67	200gf Max[[8.4]]	$_(-0.2)^{(+0.4)}$

Ordering Instruction

Series	Circuitry	Terminal Type	Lever Type	Mounting Hole/Position Pins	Versions
S21	A= SPDT B=SPST-NC C=SPST-NO	S=Solder Terminal	01,02,03.....99 (00:no Lever)	S=ø2.4(Mounting Hole)	01: Standard Specification 02: Wire cross sectional area, line length, color, 03: Wire cross sectional area, line length, color,

Basic Dimensions

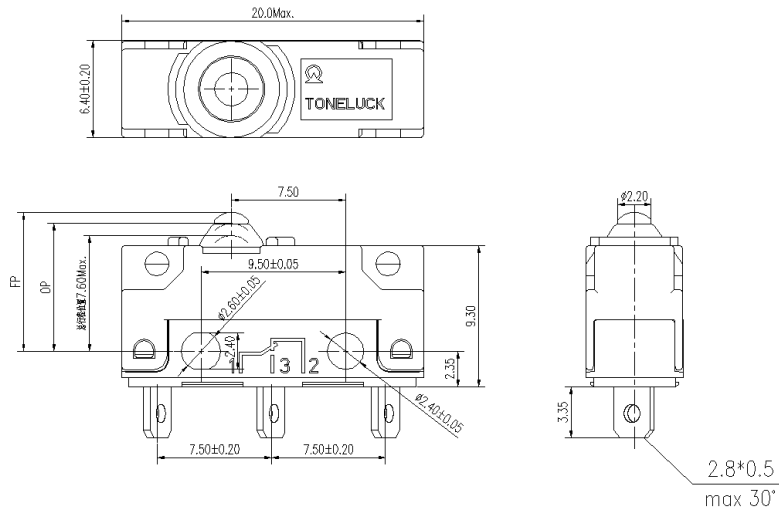

Circuit

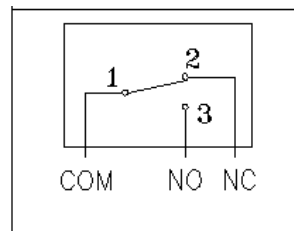
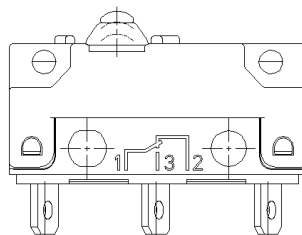

Terminal type

Type S: Solder Terminal (Twisting the terminal)

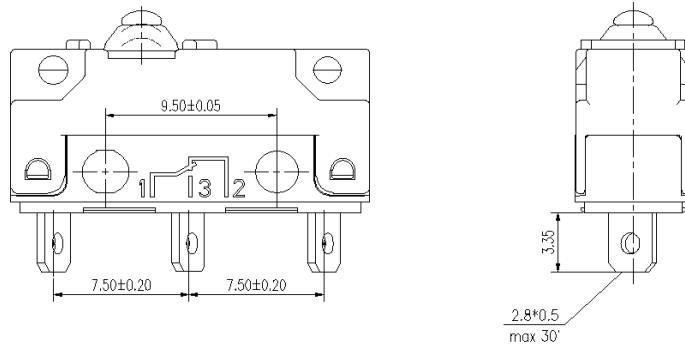

Actuation Angle

Besides actuating the micro-switch vertically, the switch could be operated by cam-shaped or chamfered sliding actuators with an approximate value of Max. 40° . Please refer to the technical specification for the specified conditions.

