

INDEX



Toneluck Micro Capacity

- ◇ Testing and R & D
- ◇ Mold Design
- ◇ Plastic Injection

Micro switch Selection Guide

1

Standard Levers for MQS-2xx & E-series

3

MQS-1 Series ----- Sub-miniature Switch

6



MQS-1s Series ----- Sub-miniature Switch

11



MQS-4 series ----- Sub-miniature Switch

14



E4~E6 Series ----- Miniature Switch

19



E8 Series ----- High Tracking Resistance Switch

21



L Series ----- Sensitive Light Force Switch

23



MQS-216 Series ----- Miniature Switch

26



MQS-210H Series ----- T150 Miniature Switch

30



THK-2 Series ----- Quick Action Leaf Switch

34



Capabilities

- R&D and Testing



Toneluck incorporates all the manufacturing processes in her manufacturing complex in Huizhou, China:

- ◇ **R & D**
- ◇ **Mold Design**
- ◇ **Plastic Injection**
- ◇ **Metal Stamping**
- ◇ **Electro-plating**
- ◇ **Process Engineering**
- ◇ **Assembly & QC**

Since 1976 when Toneluck was first established as a small family business, we know "quality" and "reliability" are not only applied to our products, but the whole process. Therefore, different statistical tools (Cpk, SPC, GR&R, etc.) and state-of-the-art testing equipments are used in all processes.



Salt-mist Tester



Application test

Toneluck Micro is a dynamic company concentrates at high precision micro switches and components for the modern control systems. Applications for these precision control components range from general office equipments, household appliances to the highly accurate control functions in industrial equipments and automobiles.



Vibration & Shock Testing



Environment simulator



UL/VDE certified testing load up to 25A, 200C.

Molds Design

High precision control components will never be available without precision molds and tools. Our Molds Department not only serves our standard products development, but also serves our customers' custom-made designs and solutions. This enable Toneluck to offer quick prototypes for customers during their design-in stage. Therefore, besides the standard micro-switches, you can also find different kind of gears and other control elements in our production lines.

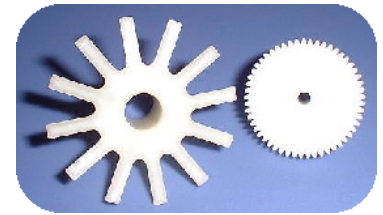

Custom-made gears



EDM machines



Wire-cut machines

Optical Gages (2D and 3D) are widely used in measuring of parts and molds dimensions. With these gages, we can carry out reliability and capability study easily by using statistical tools such as Cpk, SPC and GR&R.



2D optical gage

Plastic Injections

Plastic parts for our micros and control components are all made by our in-house injection machines from 20 tons to 110 tons. Toneluck is fully supported by major injection machine suppliers from Europe who guarantee high precision of the finished parts for your control systems.



Toneluck Micro Selection Guide

Basic Switch (T85)

Model	Op. Temp.	Tracking Resistance	Ratings	Endurance		Op. force	Page
				UL/cUL	VDE		
E41	25T85	175V	0.1A 125/250VAC	6,000	50,000	55 ~ 400gf	14
E42	25T85	175V	16(4) 125/250VAC 1/2HP 125VAC; 3/4HP 250VAC 0.4A/125VDC; 0.2A/250VDC	6,000	50,000	55 ~ 400gf	14
E43	25T85	175V	22(8)A 125/250VAC 1HP 125VAC 2HP 250VAC 15.1A 125/250VAC	6,000 100,000	10,000	160 ~ 400gf	14
L41	25T85	175V	0.1A 125/250VAC	100,000	50,000	10 ~ 75gf	18
L42	25T85	175V	UL: 5A 125/250VAC VDE: 3A 125/250VAC	100,000	50,000	10 ~ 75gf	18
MQS-216	25T85	175V	16(4) 125/250VAC 1/2HP 125VAC; 3/4HP 250VAC 0.4A/125VDC; 0.2A/250VDC	6,000	50,000	55 ~ 400gf	21

Basic Switch (T125)

MQS-2	25T125	250V	16A 125/250VAC 5A 40VDC (UL)	6,000	50,000	55 ~ 400gf	29
E51	25T125	250V	0.1A 125/250VAC	6,000	50,000	55~400gf	14
E52	25T125	250V	16(4) 125/250VAC 1/2HP 125VAC; 3/4HP 250VAC 0.4A/125VDC; 0.2A/250VDC	6,000	50,000	55~400gf	14
E53	25T125	250V	22(8)A 125/250VAC 1HP 125VAC 2HP 250VAC 15.1A 125/250VAC	6,000 100,000	10,000	160 ~ 400gf	14
L51	25T125	250V	0.1A 125/250VAC	100,000	50,000	10 ~ 75gf	18
L52	25T125	250V	UL: 5A 125/250VAC VDE: 3A 125/250VAC	100,000	50,000	10 ~ 75gf	18
MQS-216T	25T125	250V	16(4) 125/250VAC 1/2HP 125VAC; 3/4HP 250VAC 0.4A/125VDC; 0.2A/250VDC	6,000	50,000	55 ~ 400gf	21

High Tracking Resistance

E81	25T125	550V	0.1A 125/250VAC	6,000	50,000	55 ~ 400gf	16
E82	25T125	550V	16(4) 125/250VAC 1/2HP 125VAC; 3/4HP 250VAC 0.4A/125VDC; 0.2A/250VDC	6,000	50,000	55 ~ 400gf	16
E83	25T125	550V	22(8)A 125/250VAC 1HP 125VAC 2HP 250VAC 15.1A 125/250VAC	6,000 100,000	10,000	160 ~ 400gf	16

Basic Switch (T150)

E61	25T150	250V	0.1A 125/250VAC	6,000	50,000	55~400gf	14
E62	25T150	250V	10A 125/250VAC (UL) 16A 125/250VAC (VDE) 1/2HP 125/250VAC 1A 30VDC	100,000	50,000	55 ~ 400gf	14
E63	25T150	250V	22(8)A 125/250VAC 1HP 125VAC 2HP 250VAC 15.1A 125/250VAC	6,000 100,000	10,000	160 ~ 400gf	14
L61	25T150	250V	0.1A 125/250VAC	100,000	50,000	10 ~ 75gf	18
L62	25T150	250V	UL: 5A 125/250VAC VDE: 3A 125/250VAC	100,000	50,000	10 ~ 75gf	18
MQS-210H	25T150	250V	10A 125/250VAC 1/2HP 125/250VAC 1A 30VDC	100,000	-	55 ~ 400gf	25

Approvals

Almost all Toneluck micros are tested according to EN 61058-1 (VDE 0630) and carry either the standard European test mark ENEC-VDE or the VDE test mark. Licenses for the USA and Canada are granted according to UL 1054 and C 22.2 - 55 respectively:

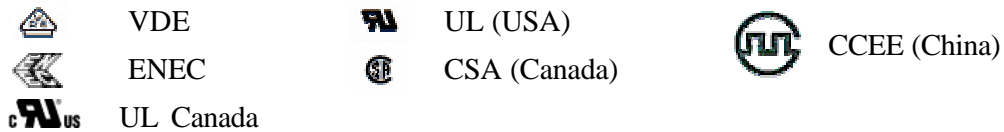

Electrical Ratings

The maximum permissible electrical load is specified and marked on the switch. Most Toneluck micros are suitable for both resistive and motor loads. The rated current for the motor load is specified in brackets, e.g. 16 (4) A 250 V~. By default, these ratings are tested according to UL 1054 / CSA 22.2-55 or EN61058-1 with inductive load and resistive load respectively. Some switches also come with DC ratings or ratings for specific loads. Please consult Toneluck representatives for more details.

Electrical life

In Europe, switches that are expected to be actuated more than 2,000 times a year must be tested and approved for an electrical life of 50,000 cycles min. Most of Toneluck micros meet this requirement and marked with symbol 5E4. In USA market, our switches are usually tested for 6,000 cycles for general purposes. Extended life versions which are tested for 100,000 cycles min. are available for some micros.

Gold-plated Contacts

We recommend using Toneluck micros with gold-plated contacts for mini-watt applications in which the electrical rating is just a few mA, 12 V or less. We also recommend gold-plated contacts for applications that are rarely actuated or in acidic or high humidity atmospheres, for example, inside a gas water heater. However, we don't recommend customers using gold-plated contacts micros in high current switching because the high current will just have the thin gold layer broken. If you have any question, we will be glad to advise you on special applications.

Tracking Resistance (CTI / PTI)

Most of Toneluck micros are made of insulating materials with a **Proof Tracking Index** of PTI-175 or PTI-250. E8 series micros are made of PTI-550 material. PTI-250 switch means this switch is capable of resisting 50 drops of test fluid (according to VDE and UL) at a test voltage of 250V without producing any leakage current. Current leakage on the switch body surface may lead to fire hazard. PTI in VDE is similar to that of the Comparative Tracking Index (CTI) in UL.

Standard Levers for MQS-2xx & E series Basic Switches

(All dimensions in [mm], force in gram)

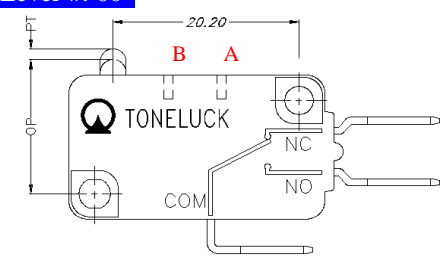
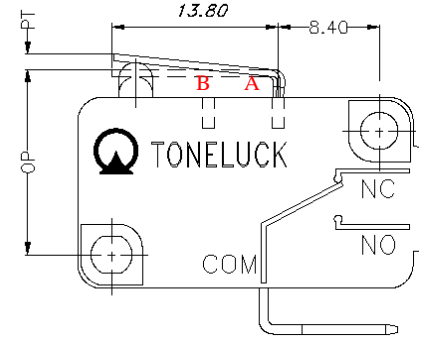
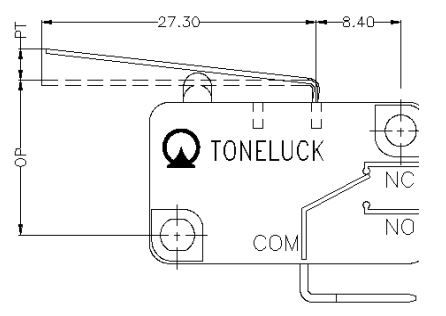
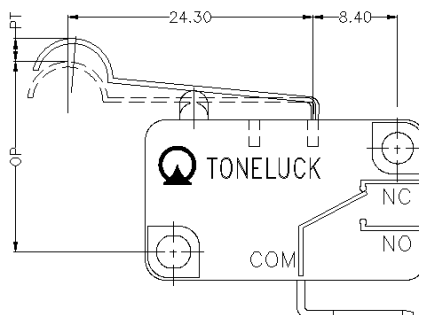
Lever Type	Lever position	Op. force(gf)	RF (min)	OP	PT (max)	OT (min)	MD (max)
Lever #: 00 	-	K: 55 ± 15	10	14.7±0.5	1.2	1.25	0.40
		L: 100 ± 25	20				
		M: 160 ± 30	50				
		N: 200 ± 30	55				
		P: 350 ± 50	80				
Lever #: 01 	A	K: 55 ± 15	10	15.3±0.5	1.6	1.5	0.5
		L: 100 ± 25	20				
		M: 160 ± 30	50				
		N: 200 ± 30	55				
		P: 350 ± 50	80				
	B	K: 30 ± 15	10	15.3±1.1	3.0	2.4	0.75
		L: 50 ± 15	15				
		M: 80 ± 20	30				
		N: 100 ± 20	40				
		P: 175 ± 30	50				
Lever #: 02 	A	K: 30 ± 15	10	15.3±1.5	3.3	2.5	1.2
		L: 50 ± 15	15				
		M: 75 ± 20	30				
		N: 95 ± 20	40				
		P: 170 ± 30	50				
	B	K: 20 ± 8	5	15.3±2.3	6.0	4.8	1.65
		L: 30 ± 10	10				
		M: 40 ± 15	15				
		N: 50 ± 15	20				
		P: 85 ± 20	30				
Lever #: 03 	A	K: 30 ± 15	10	18.7±1.5	2.8	2.4	1.1
		L: 55 ± 15	15				
		M: 85 ± 20	30				
		N: 105 ± 20	40				
		P: 180 ± 30	50				
	B	K: 20 ± 8	5	18.7±2.1	5.5	4.1	1.6
		L: 30 ± 10	10				
		M: 45 ± 15	15				
		N: 55 ± 15	20				
		P: 100 ± 25	30				

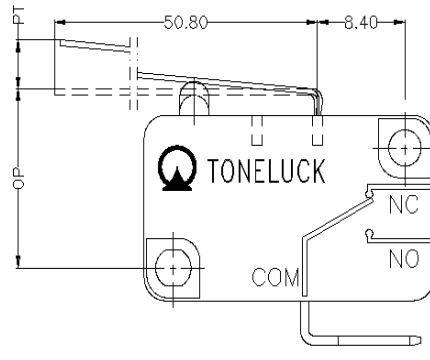
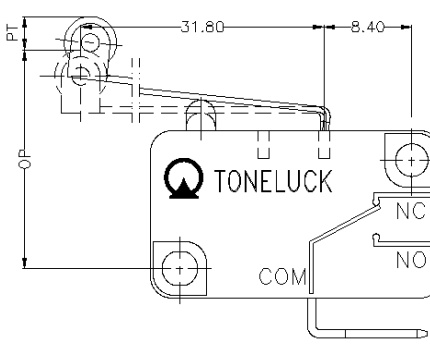
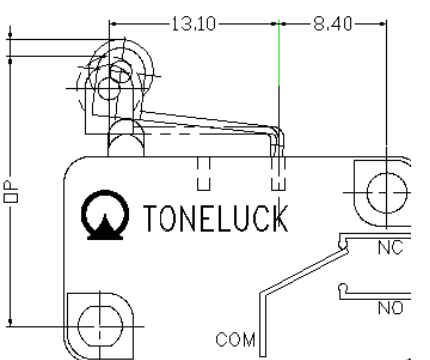
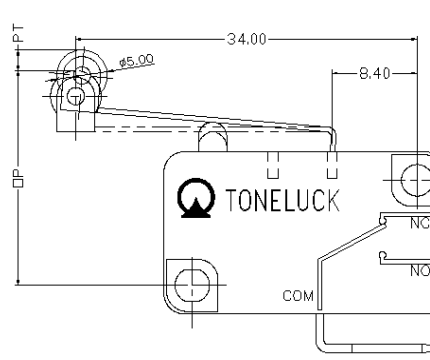
Lever Type	Lever position	Op. force (gf)	RF min	OP	PT (max)	OT (min)	MD (max)
Lever #: 04 	A	K: 12 ± 5	4	15.3±2.5	6.5	4.4	2.2
		L: 25 ± 10	8				
		M: 40 ± 15	15				
		N: 50 ± 15	20				
		P: 85 ± 20	30				
	B	K: 7 ± 5	2	15.3±4.3	11.5	8.3	3.5
		L: 15 ± 8	5				
		M: 20 ± 8	8				
		N: 25 ± 10	10				
		P: 55 ± 15	15				
Lever #: 05 	A	K: 20 ± 10	5	20.7±1.5	3.7	3.3	1.3
		L: 40 ± 15	10				
		M: 60 ± 15	25				
		N: 75 ± 20	30				
		P: 140 ± 30	45				
	B	K: 12 ± 5	4	20.7±2.2	7.5	5.5	2.4
		L: 20 ± 10	8				
		M: 35 ± 15	12				
		N: 40 ± 15	15				
		P: 80 ± 20	25				
Lever #: 12 	A	K: 55 ± 15	10	20.7±0.5	1.6	1.5	0.5
		L: 100 ± 25	20				
		M: 160 ± 30	50				
		N: 200 ± 30	55				
		P: 350 ± 50	80				
	B	K: 30 ± 15	10	20.7±1.1	3.0	2.4	0.75
		L: 50 ± 15	15				
		M: 80 ± 20	30				
		N: 100 ± 20	40				
		P: 175 ± 30	50				
Lever #: 13 	A	K: 30 ± 15	10	20.7±0.5	3.3	2.5	1.2
		L: 50 ± 15	15				
		M: 80 ± 20	30				
		N: 100 ± 20	40				
		P: 175 ± 30	50				
	B	K: 20 ± 8	5	20.7±2.2	6.0	4.8	1.6
		L: 30 ± 10	10				
		M: 40 ± 15	10				
		N: 50 ± 15	15				
		P: 90 ± 20	30				

Other standard levers

<p>No.#06</p>	<p>No.#07</p>
<p>No.#09</p>	<p>No.#10</p>
<p>No.#16</p>	<p>No.#17</p>
<p>No.#08</p>	<p>No.#18</p>
<p>No.#11</p>	

Note: Please contact Toneluck or her representatives for more levers

Specifications

<u>Model Ref.</u>	<u>Temp.</u>	<u>UL/VDE Ratings</u>	<u>Endurance (min)</u>
MQS- 1	40T85	5A 125/250VAC (UL) 3A 250VAC (VDE)	50,000 cycles
MQS-14	40T125	10(2)A 125/250VAC	10,000 cycles
MQS-15	40T85	10(2)A 125/250VAC	10,000 cycles
MQS-16	40T125	0.1A 125/250VAC	50,000 cycles
MQS-17	40T85	0.1A 125/250VAC	50,000 cycles
MQS-18	40T125	5A 125/250VAC	50,000 cycles
MQS-19	40T85	5A 125/250VAC	50,000 cycles
MQS-11	40T85	0.2A/48V DC *	500,000 cycles
MQS-1D	40T85	3A/24VDC *	100,000 cycles
MQS-1E	40T125	3A/24VDC *	100,000 cycles
Mechanical Life:		1,000,000 cycles	
Insulation Resistance:		100 MΩ min.	
Dielectric Strength:		1000VAC for 60 +/- 5 sec	
Housing:		UL 94V0 Thermoplastic	



Ordering qty: 200pcs
Switch with lever: 1000pcs

Ordering Instructions

MQS-14	A	P	F2	01	-	S	01
---------------	----------	----------	-----------	-----------	----------	----------	-----------

Type Ref.	<u>Circuitry</u>	<u>Terminals Type</u>	<u>Op. force</u>	<u>Lever Type</u>	<u>Contact Plating</u>	<u>Versions</u>
A=SPDT		P= PCB terminals (straight)	F1	01, 02, 03 .99	S= Std. Silver	Standard: 01
B=SPST -NC		A= Solder terminals	F2	B1, B2, B3 .ZZ	G= Gold over silver.	Custom-made: 02, 03 ...
C=SPST -NO		B= PCB terminal (right bent)	F3	etc.	(other spec:	(Default: 01)
		C= PCB terminal (left bent)	F4	(no lever: 00)	A, B, C ..)	
		D= Quick Connect terminals				

* MQS-14/MQS-15: only F4 is available
* MQS-11/1D/1E: Low voltage devices, no UL/VDE marks

Terminal Types

Type A: Solder Terminal

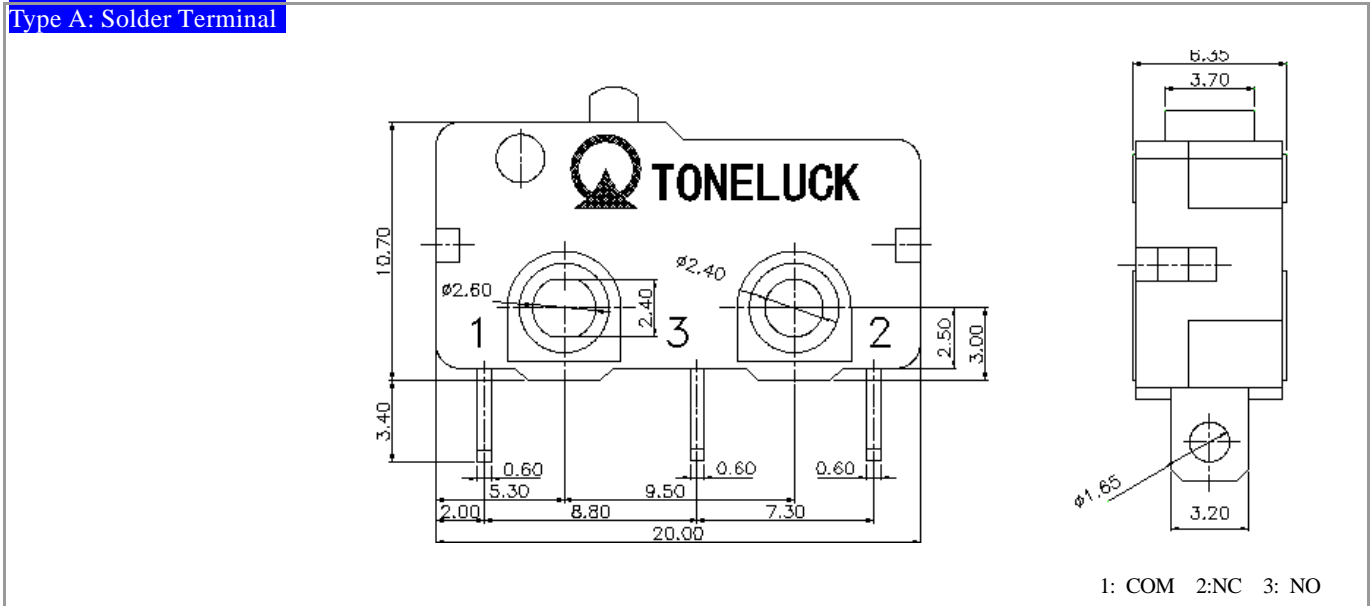

Type P: PCB Terminal

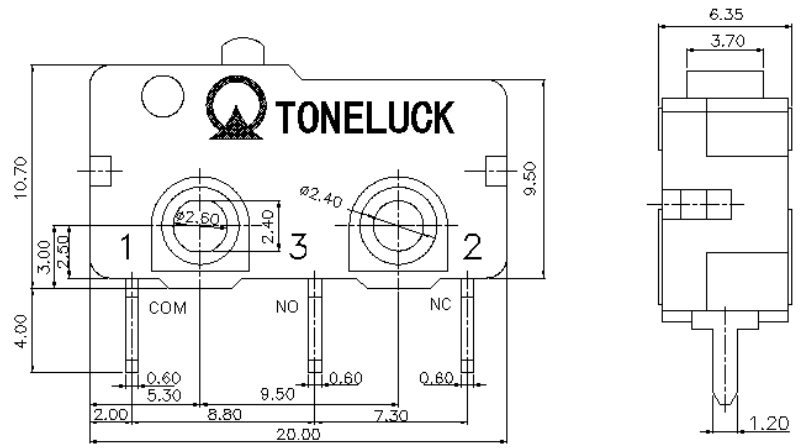

Type D: Quick Connect Terminal

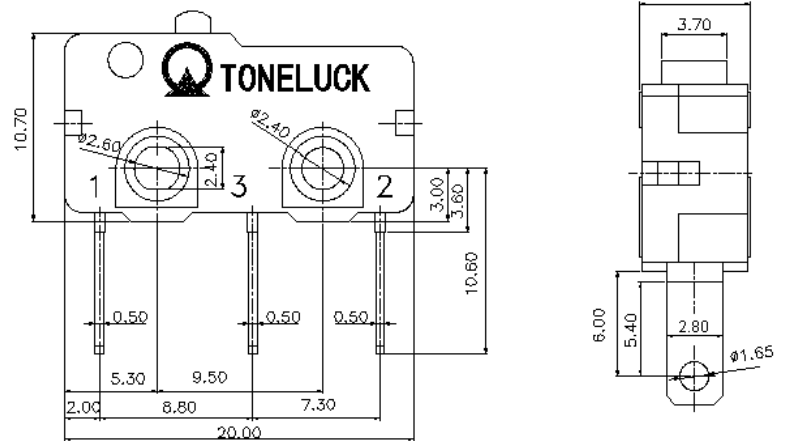

Type B: PCB Terminal (Right Bent)

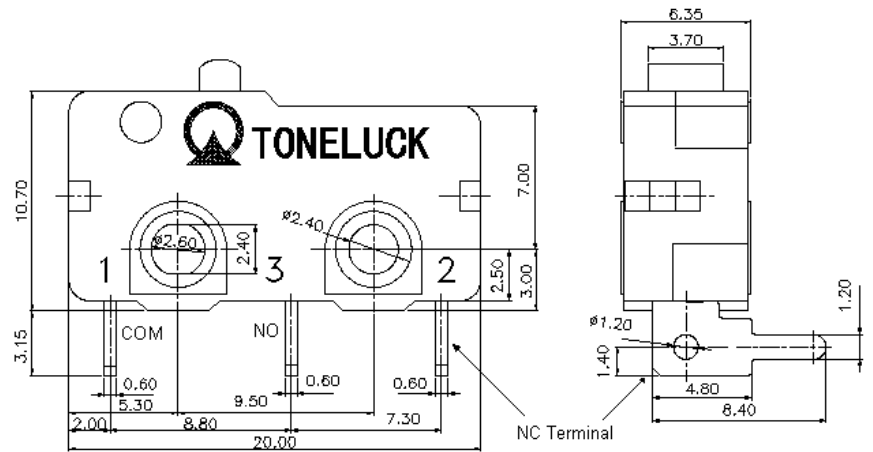

Type C: PCB Terminal (Left Bent)

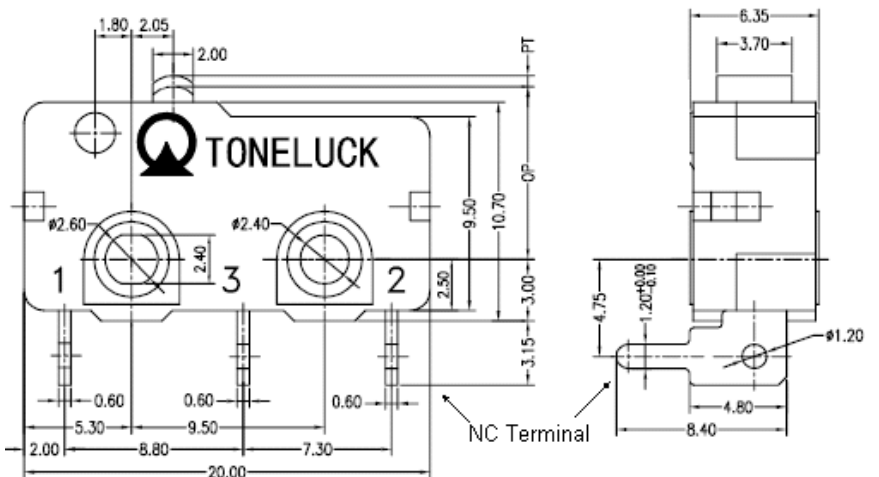

Standard Levers

lever type	Drawing & dimensions	OF (gf)	RF (gf) Max	OP (mm)	PT(mm) Max	OT(mm) Min	MD (mm)Max	FP (mm) max
00		F1= 80 ± 20	10	8.4±0.3	0.6	0.5	0.2	-
		F2=130 ± 30	25	8.4±0.3	0.6	0.5	0.2	-
		F3=160 ± 30	35	8.4±0.3	0.6	0.5	0.2	-
		F4=230 ± 40	55	8.4±0.3	0.6	0.5	0.2	-
01		F1=20 ± 10	5	9.4±1.0	3.0	1.0	1.0	12.5
		F2=30 ± 10	5	9.4±1.0	3.0	1.0	1.0	12.5
		F3=40 ± 15	8	9.4±1.0	3.0	1.0	1.0	12.5
		F4=50 ± 20	10	9.4±1.0	3.0	1.0	1.0	12.5
02		F1=25 ± 10	5	9.4±1.0	3.0	1.0	1.0	12.5
		F2=35 ± 15	5	9.4±1.0	3.0	1.0	1.0	12.5
		F3=45 ± 15	8	9.4±1.0	3.0	1.0	1.0	12.5
		F4=65 ± 20	15	9.4±1.0	3.0	1.0	1.0	12.5
03		F1= 10 ± 5	2	10.0±1.5	3.7	1.5	2.0	13.7
		F2=20 ± 10	5	10.0±1.5	3.7	1.5	2.0	13.7
		F3=25 ± 10	5	10.0±1.5	3.7	1.5	2.0	13.7
		F4=35 ± 10	5	10.0±1.5	3.7	1.5	2.0	13.7
04		F1=40 ± 15	8	9.0±0.8	1.8	0.5	0.8	10.8
		F2=65 ± 20	15	9.0±0.8	1.8	0.5	0.8	10.8
		F3=100 ± 30	25	9.0±0.8	1.8	0.5	0.8	10.8
		F4=120 ± 30	30	9.0±0.8	1.8	0.5	0.8	10.8
05		F1=30 ± 10	8	9.2±0.8	2.8	0.5	0.8	11.3
		F2=40 ± 20	10	9.2±0.8	2.8	0.5	0.8	11.3
		F3=60 ± 20	15	9.2±0.8	2.8	0.5	0.8	11.3
		F4=75 ± 25	25	9.2±0.8	2.8	0.5	0.8	11.3

lever type	Drawing & dimensions	OF (gf)	RF (gf) Max	OP (mm)	PT(mm) Max	OT(mm) Min	MD (mm)Max	FP (mm) max
06		F1=15 ±10	5	15.0±0.8	2.5	1.0	1.0	17.5
		F2=30 ± 10	5	15.0±0.8	2.5	1.0	1.0	17.5
		F3=40 ±15	8	15.0±0.8	2.5	1.0	1.0	17.5
		F4=55 ± 20	15	15.0±0.8	2.5	1.0	1.0	17.5
07		F1=20 ± 10	5	10.8±0.8	2.6	1.0	1.0	13.6
		F2=35 ± 15	5	10.8±0.8	2.6	1.0	1.0	13.6
		F3=45 ± 15	10	10.8±0.8	2.6	1.0	1.0	13.6
		F4=65 ± 20	15	10.8±0.8	2.6	1.0	1.0	13.6
08		F1=30 ± 15	5	12.0±1.0	3.0	0.8	0.8	14.5
		F2=40 ± 15	8	12.0±1.0	3.0	0.8	0.8	14.5
		F3=50 ± 20	15	12.0±1.0	3.0	0.8	0.8	14.5
		F4=65 ± 20	20	12.0±1.0	3.0	0.8	0.8	14.5
09		F1=25 ± 10	5	12.5±0.8	2.5	0.6	0.8	15.2
		F2=40 ± 15	8	12.5±0.8	2.5	0.6	0.8	15.2
		F3=50 ± 20	15	12.5±0.8	2.5	0.6	0.8	15.2
		F4=65 ± 20	20	12.5±0.8	2.5	0.6	0.8	15.2
10		F1=12gf (max)	3	15.5±2.0	5.5	2.0	2.5	22.0

lever type	Drawing & dimensions	OF (gf)	RF (gf) Max	OP (mm)	PT(mm) Max	OT(mm) Min	MD (mm)Max	FP (mm) max
11		F1=20 ± 10	5	13.0±0.8	2.5	1.0	1.0	15.3
		F2=40 ± 15	5	13.0±0.8	2.5	1.0	1.0	15.3
		F3=50 ± 20	10	13.0±0.8	2.5	1.0	1.0	15.3
		F4=65 ± 20	15	13.0±0.8	2.5	1.0	1.0	15.3
12		F1=20 ± 10	5	13.8±1.0	2.5	0.8	1.0	16.4
		F2=40 ± 15	8	13.8±1.0	2.5	0.8	1.0	16.4
		F3=50 ± 20	10	13.8±1.0	2.5	0.8	1.0	16.4
		F4=65 ± 20	15	13.8±1.0	2.5	0.8	1.0	16.4

Note: For more levers, please contact Toneluck or her sales representatives.

Specifications

Ratings:	3A/250VAC UL/VDE 5A/125VAC UL/VDE
Electrical Life:	50,000 cycles min.
Mechanical Life:	1,000,000 cycles
Operating Temp:	-25° C ~ +85° C
Insulation Resistance:	100 MΩ min.
Dielectric Strength:	1000VAC for 60 +/- 5 sec
Housing:	Thermosetting Plastic
Proof Tracking Index:	175V
Contacts:	Silver Alloy (standard) Gold plated



Order quantity: 200pcs
Switch with lever: 1000pcs

Ordering Instructions

MQS-1s	A	P	F1	01	-	S	01
<u>Circuitry</u>	<u>Terminals Type</u>	<u>Operating Force</u>	<u>Lever Type</u>	<u>Contact Plating</u>	<u>Versions</u>		
A=SPDT	A= Solder terminals	F1	01, 02, 03 .99	S= Std. Silver	Standard: 01		
B=SPST -NC	D= Quick Connect terminals	(only F1 available)	B1, B2, B3 ..ZZ	G= Gold over silver.	Custom-made:		
C=SPST -NO			(00 = no lever)		02, 03, 04 ...		
					(Default: 01)		

Terminal Types

Type A: Solder Terminal

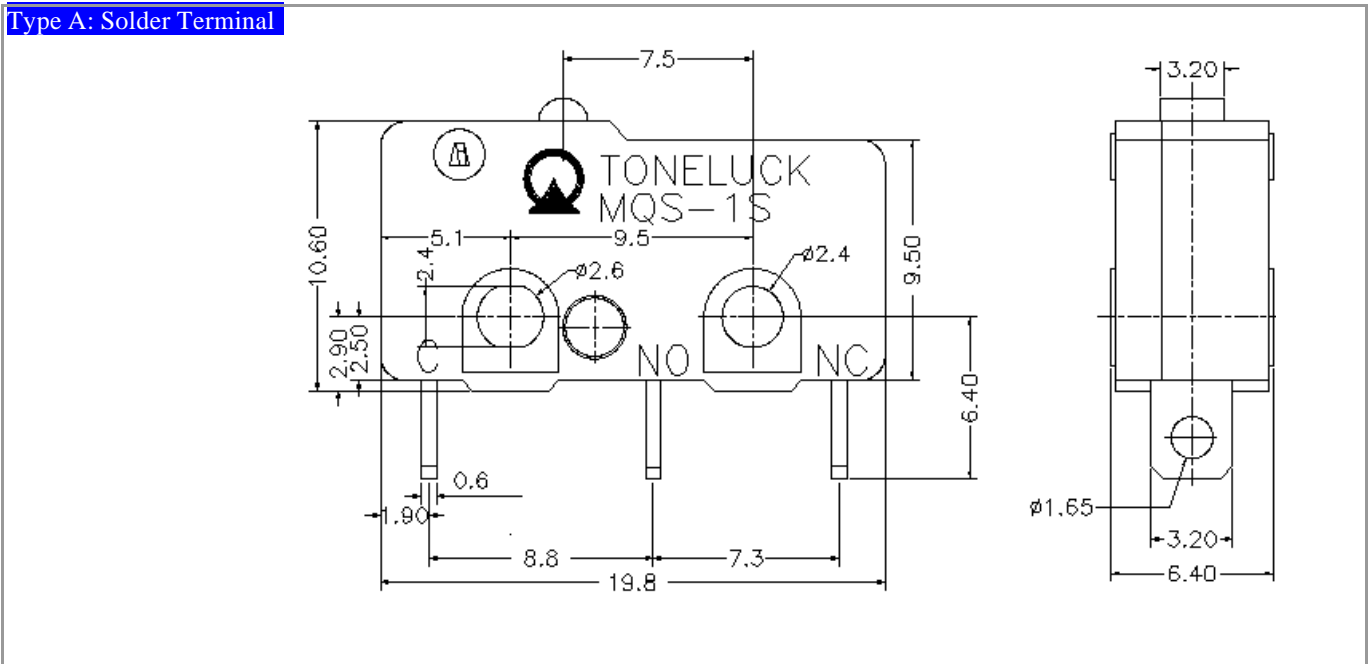

Type D: Quick Connect Terminal

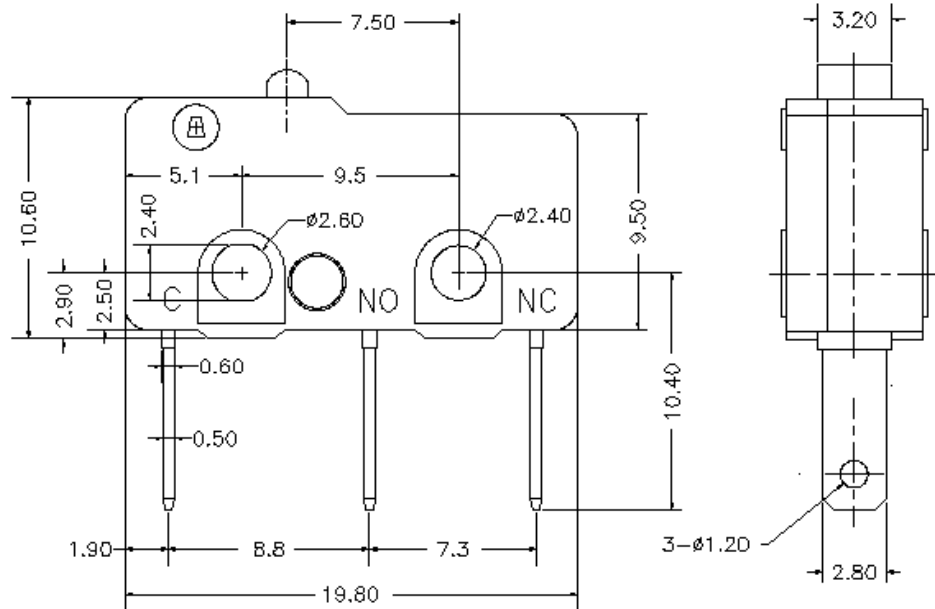

Standard Levers

Lever Type	Dimensions	OF (gf)	RF (gf) Min	OP mm	PT mm	OT mm	MD(mm) Max	FP(mm) Max
00		48 +/- 12gf	20	8.4 ± 0.5	0.5 max	0.3	0.1	12.0
01		11 ± 5	3	9.5 ± 1.0	1.9	1.2	0.8	11.8
02		12 ± 5	4	9.5 ± 1.0	1.3	1.2	0.8	11.5

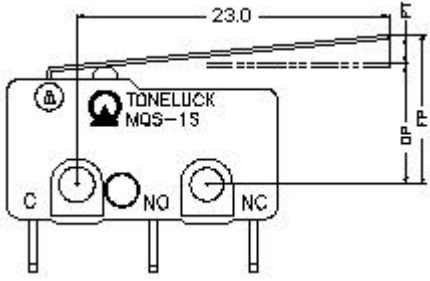
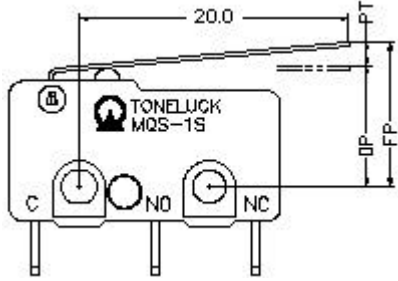
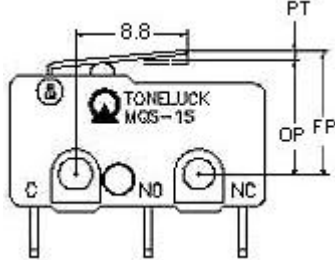
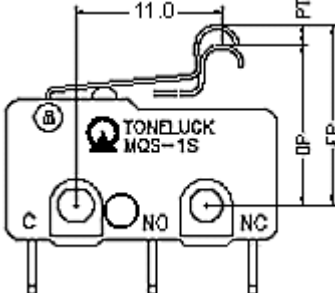
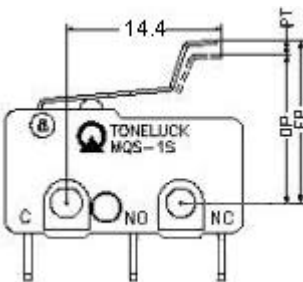
Lever Type	Dimensions	OF (gf)	RF (gf) Min	OP mm	PT mm	OT mm	MD(mm) Max	FP(mm) Max
03		8± 5	2	9.5 ± 1.5	2.6	1.5	0.8	12.5
04		10± 5	2	9.6 ± 1.5	2.3	1.5	0.8	12.2
05		20± 10	6	9.1 ± 0.5	1.2	1.0	0.4	10.6
06		17± 7	5	12.8 ± 1.0	1.3	1.0	0.8	14.5
07		12± 6	3	13.2± 1.0	1.7	1.2	0.8	15.1

Note: for custom-made or more levers, please contact Toneluck or her sales representatives.

Specifications

Electrical Rating	2A/12VDC, 40T85 10mA/12VDC, 40T85		
Electrical Life:	200,000 cycles min.		
Mechanical Life:	1,000,000 cycles		
Degree of Protection:	<u>Model No.</u>	<u>Actuation side</u>	<u>Terminal side</u>
	MQS-41	IP 40	IP 00
	MQS-42	IP 67	IP 00
	<i>(MQS-43: under development)</i>	MQS-43	IP 67
Contact Resistance:	50mΩ max. (initial)		
Operating Force:	130gf max. (MQS-41) 180gf max. (MQS-42/MQS-43)		
Insulation Resistance:	100 MΩ min.		
Dielectric Strength:	500VAC for 60 +/- 5 sec		
Contact Gap:	< 3mm		
Housing:	UL 94V-2 Thermoplastic		

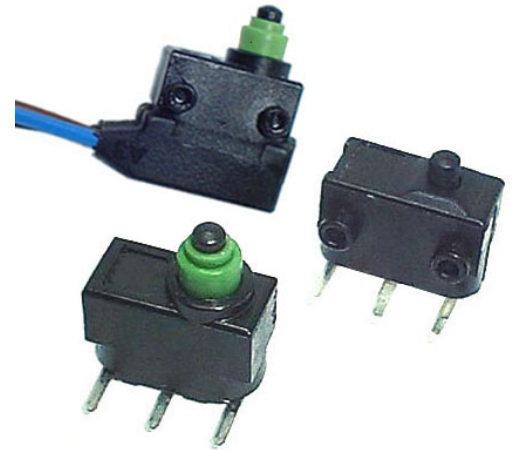

Ordering Instructions

MQS-41
1
A
A
00
-
Ag
01

<u>Model Type</u>	<u>Current Rating</u>	<u>Location Pins</u>	<u>Terminal configuration</u>	<u>Lever Type</u>	<u>Contact-plating</u>	<u>Versions</u>
MQS-41	1= 2A/12V DC	A = Side A	A=Angled PCB pins, side A	01, 02, 03 .99	Ag= Silver	Standard version: 01
MQS-42	2= 10mA/12VDC	B = Side B	B=Angled PCB pins, side B	A1, A2, A3 .ZZ	Au= Gold	Custom-made: 02, 03 ...
MQS-43	3= 0.1A/250VAC	C = Both Sides N = No location Pin	C= Straight PCB pins D= Straight crimped pcb pins E= Solder terminal F= Cable outlet (300mm) G= Cable outlet (150mm)	etc. (no lever: 00)	Others: A1, A2 ...	(Default: 01)

** MQS-43: under development*

Common Characteristics:

MQS-41/MQS-42: SPDT
MQS-43: SPDT, SPST-NC, SPST-NO

Movement Differential: 0.4 mm max.
Pre-travel Distance: 1.2mm max.
Over-travel Distance: 1.2mm min.

Standard Contact Plating:

2A/12VDC: Silver
10mA/12VDC: Gold plated
0.1A/250VAC: Silver

* Gold over silver version available

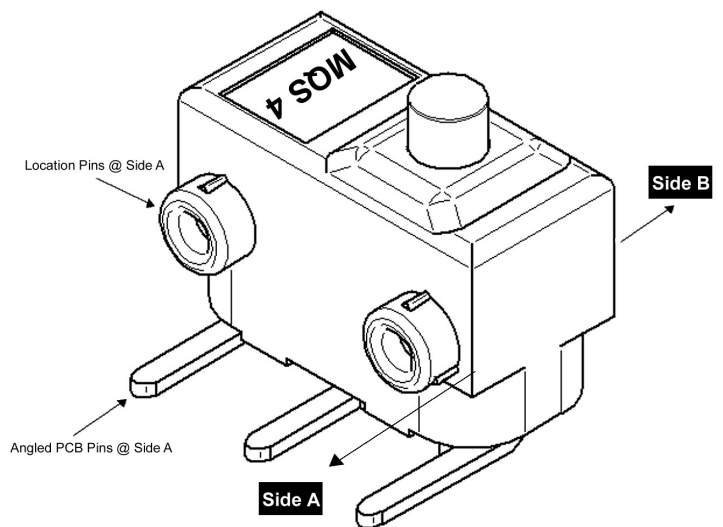

** Direction: Plunger up, towards users.*

Model Types

MQS-41



MQS-42

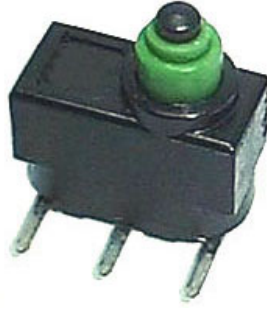

MQS-43



Dimensions & Drawings

MQS-41 Solder Terminal

Standard Items:

Part-number	Rating	Position Pin
MQS-411AE00-Ag01	2A/12V DC	Side A
MQS-411BE00-Ag01	2A/12V DC	Side B
MQS-411CE00-Ag01	2A/12V DC	Both Sides
MQS-412AE00-Au01	10mA/12V DC	Side A
MQS-412BE00-Au01	10mA/12V DC	Side B
MQS-412CE00-Au01	10mA/12V DC	Both Sides

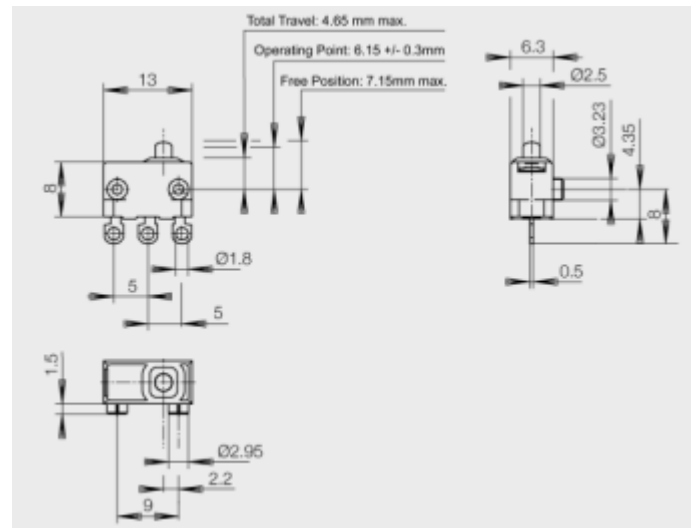

MQS-41 Angled PCB Pins

Standard Items:

Part-number	Rating	Position Pin
MQS-411AA00-Ag01	2A/12V DC	Side A
MQS-411BB00-Ag01	2A/12V DC	Side B
MQS-412AA00-Au01	10mA/12V DC	Side A
MQS-412BB00-Au01	10mA/12V DC	Side B

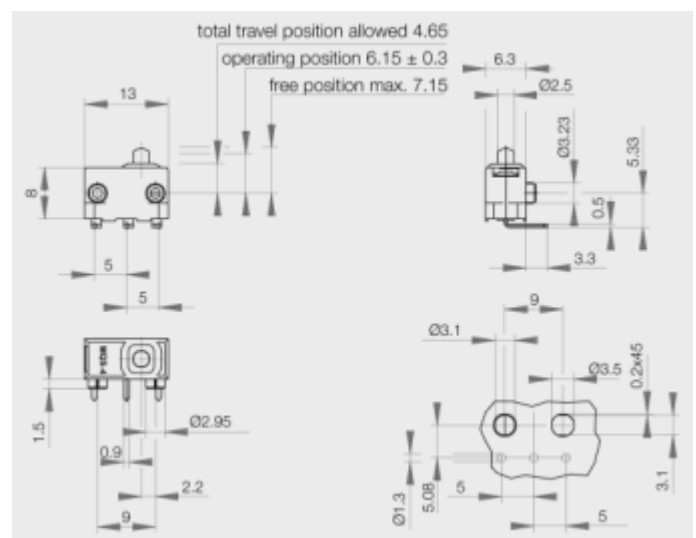

MQS-41 Straight PCB Pins

Standard Items:

Part-number	Rating	Position Pin
MQS-411AC00-Ag01	2A/12V DC	Side A
MQS-411BC00-Ag01	2A/12V DC	Side B
MQS-412AC00-Au01	10mA/12V DC	Side A
MQS-412BC00-Au01	10mA/12V DC	Side B
MQS-411NC00-Ag01	2A/12V DC	None
MQS-412NC00-Au01	10mA/12V DC	None

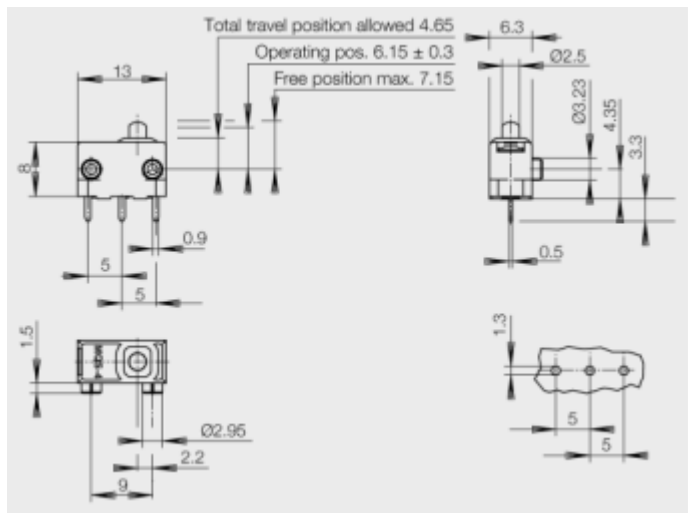

MQS-41 Crimped PCB Pins

Standard Items:

Part-number	Rating	Position Pin
MQS-411AD00-Ag01	2A/12V DC	Side A
MQS-411BD00-Ag01	2A/12V DC	Side B
MQS-412AD00-Au01	10mA/12V DC	Side A
MQS-412BD00-Au01	10mA/12V DC	Side B
MQS-411ND00-Ag01	2A/12V DC	None
MQS-412ND00-Au01	10mA/12V DC	None

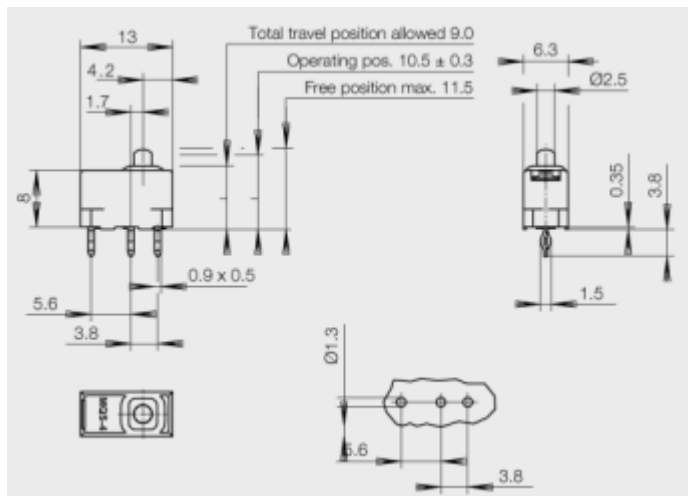

MQS-42 Solder Terminal

Standard Items:

Part-number	Rating	Position Pin
MQS-421AE00-Ag01	2A/12V DC	Side A
MQS-421BE00-Ag01	2A/12V DC	Side B
MQS-421CE00-Ag01	2A/12V DC	Both Sides
MQS-422AE00-Au01	10mA/12V DC	Side A
MQS-422BE00-Au01	10mA/12V DC	Side B
MQS-422CE00-Au01	10mA/12V DC	Both Sides

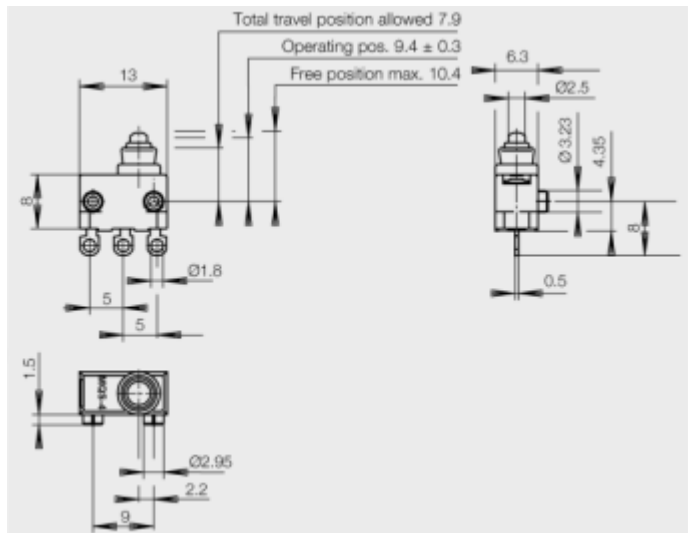

MQS-42 Angled PCB Pins

Standard Items:

Part-number	Rating	Position Pin
MQS-421AA00-Ag01	2A/12V DC	Side A
MQS-421BB00-Ag01	2A/12V DC	Side B
MQS-422AA00-Au01	10mA/12V DC	Side A
MQS-422BB00-Au01	10mA/12V DC	Side B

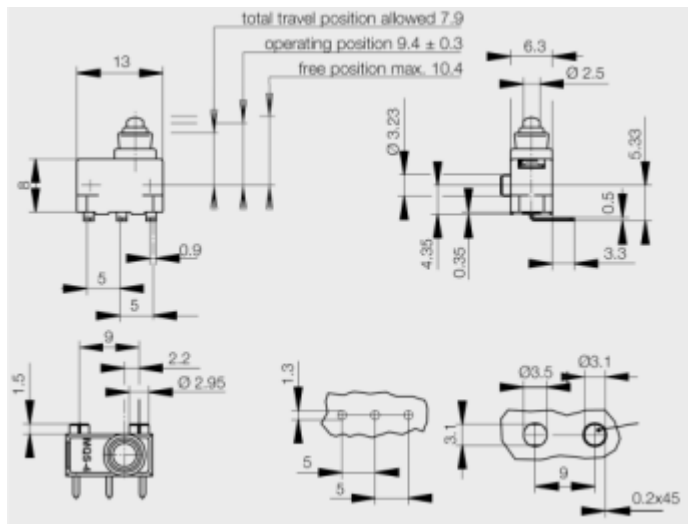

MQS-42 Straight PCB Pins

Standard Items:

Part-number	Rating	Position Pin
MQS-421AC00-Ag01	2A/12V DC	Side A
MQS-421BC00-Ag01	2A/12V DC	Side B
MQS-422AC00-Au01	10mA/12V DC	Side A
MQS-422BC00-Au01	10mA/12V DC	Side B
MQS-421NC00-Ag01	2A/12V DC	None
MQS-422NC00-Au01	10mA/12V DC	None

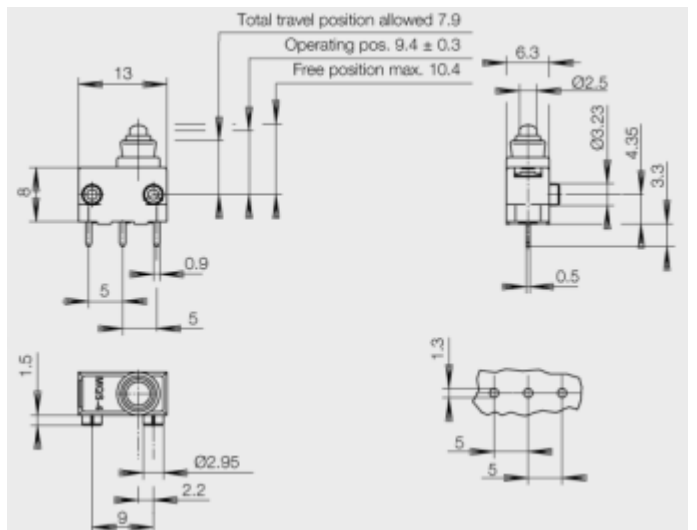

MQS-42 Crimped PCB Pins

Standard Items:

Part-number	Rating	Position Pin
MQS-421AD00-Ag01	2A/12V DC	Side A
MQS-421BD00-Ag01	2A/12V DC	Side B
MQS-422AD00-Au01	10mA/12V DC	Side A
MQS-422BD00-Au01	10mA/12V DC	Side B
MQS-421ND00-Ag01	2A/12V DC	None
MQS-422ND00-Au01	10mA/12V DC	None

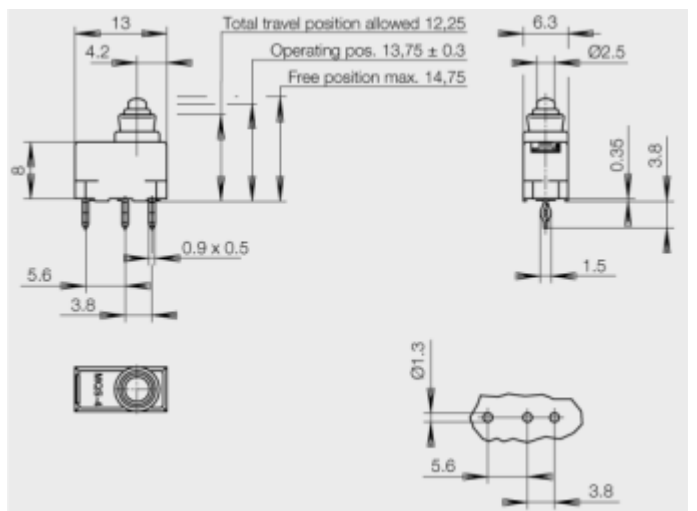

MQS-43 Cable Outlet

Standard Items:

Part-number	Rating	Position Pin & wires
MQS-431AF00-Ag01	2A/12V DC	Side A, 300mm
MQS-431BF00-Ag01	2A/12V DC	Side B, 300mm
MQS-432AF00-Au01	10mA/12V DC	Side A, 300mm
MQS-432BF00-Au01	10mA/12V DC	Side B, 300mm
MQS-431AG00-Ag01	2A/12V DC	Side A, 150mm
MQS-431BG00-Ag01	2A/12V DC	Side B, 150mm
MQS-432AG00-Au01	10mA/12V DC	Side A, 150mm
MQS-432BG00-Au01	10mA/12V DC	Side B, 150mm

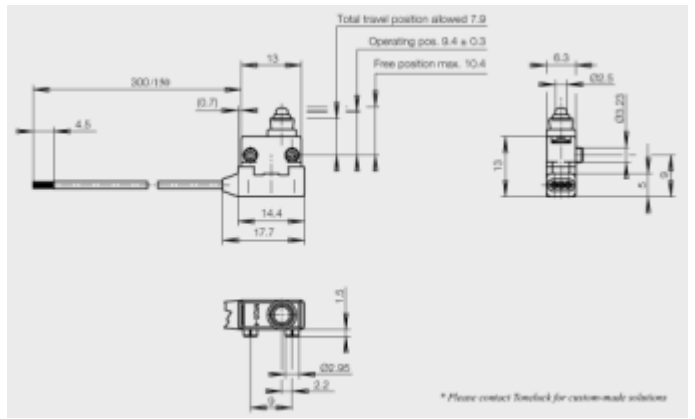

Actuation Angle

Besides actuating the micro-switch vertically, the special robust actuator design allows actuation from all directions with an approach angle as less as 40°.

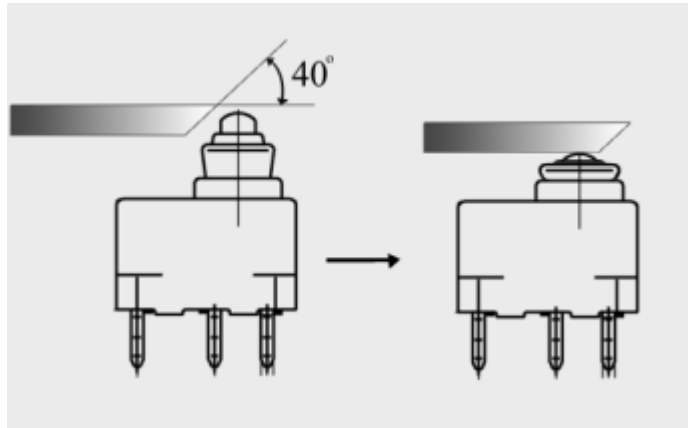

Specifications

E41 [25 T 85] :	0.1A 125/250VAC	> 50,000 cycles
E51 [25 T 125]		
E61 [25 T 150]		
E42 [25 T 85] :	16(4)A 125/250VAC	> 50,000 cycles
E52 [25 T 125]	1/2HP 125VAC; 3/4HP 250VAC	
	0.4/125VDC; 0.2/250VDC	
	10.1A/125VAC (Tungsten)	
E62 [25 T 150] :	10A 125/250VAC	>100,000 cycles
	16A 125/250VAC	> 50,000 cycles
	1/2HP 125/250VAC	
	1A/30VDC	
E43 [25 T 85] :	22(8)A 125/250VAC	>10,000 cycles
E53 [25 T 125]	15.1A 125/250VAC	>100,000 cycles
E63 [25 T 150]	1HP/125VAC	
	2HP/250VAC	
	(Op. force K & L not available for 22A model)	
Mechanical Life:	1,000,000 cycles min.	
Insulation Resistance:	100 MΩ min.	
Dielectric Strength:	1000VAC for 60 +/- 5 sec	
Housing:	UL 94V0 Thermoplastic	



Ordering qty: 200pcs
Switch with lever: 1000pcs

Ordering Instructions

E42 A K - A A 01 Ag - 01

Series	Circuitry	Operating Force	Terminal Type	Lever Position	Lever Type	Contact Type	Versions
E41~E43	A=SPDT	K	Ref. to table	A: standard position	01, 02,..99	Ag = silver	Standard: 01
E51~E53	B=SPST-NC	L		B: high gear position	A1, A2..YY	Au = gold plated	Custom-made:
E61~E63	C=SPST-NO	M		N: no lever		An = other spec.	02, 03, 04, ..99
		N			00: no lever	(n= 1, 2, 3..)	1A, 1B, 1C ..1Y
		P					

Basic Switch Dimensions

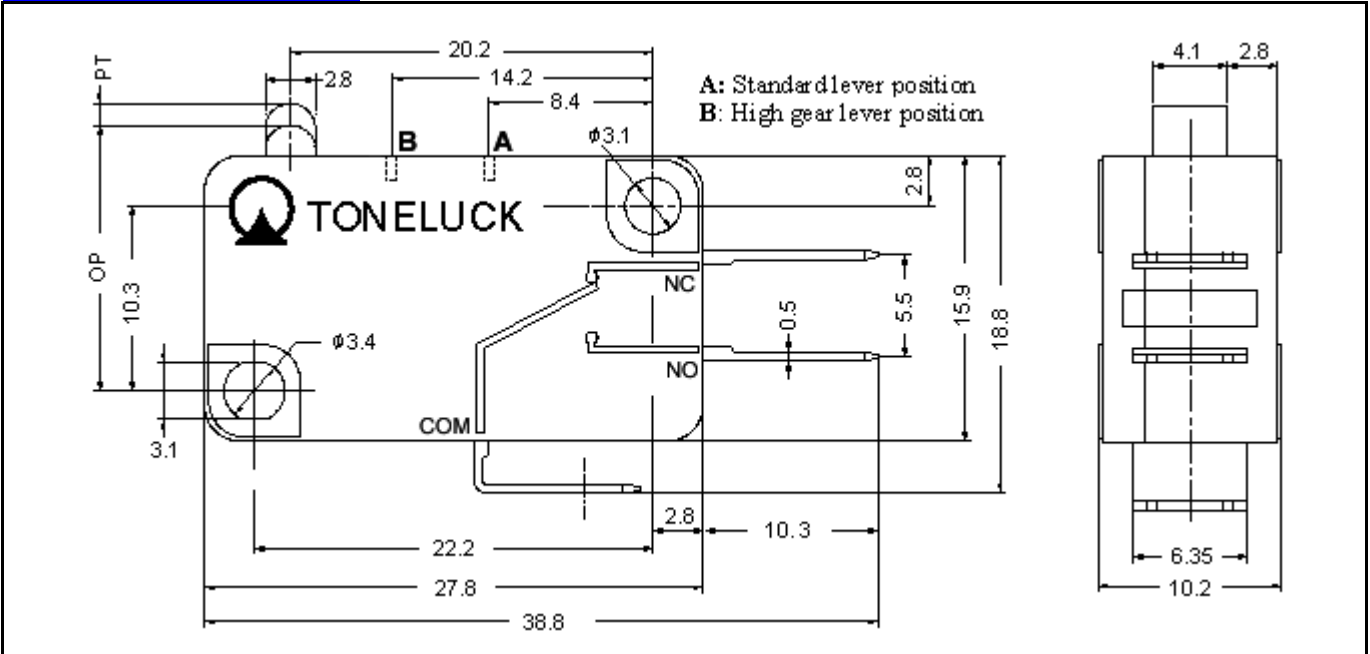

Standard Terminals

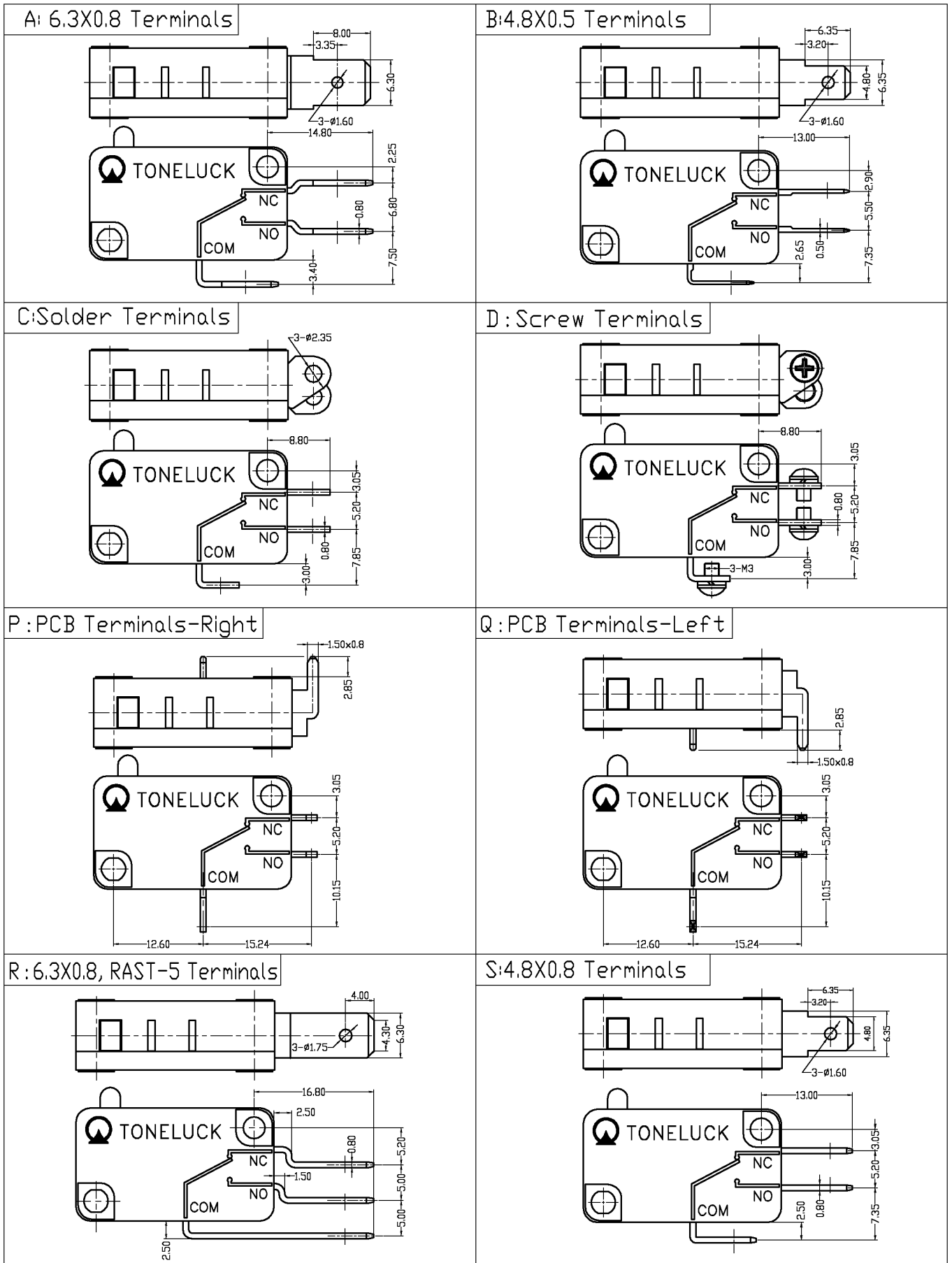

* Please refer to P.3 for standard levers and operation forces.

Specifications

E81	0.1A 125/250VAC > 50,000 cycles
E82	16(4)A 125/250VAC > 50,000 cycles 1/2HP 125VAC; 3/4HP 250VAC 0.2A/250VDC; 0.4A/125VDC 10.1A/125VAC (Tungsten)
E83	22(8)A 125/250VAC >10,000 cycles 15.1A 125/250VAC >100,000 cycles 2HP/250VAC, 1HP/125VAC (Op. force K & L are not available for 22A model)
Tracking Resistance:	PTI-550V / CTI-550V
Operating Temp:	-25 ~ +125C
Mechanical Life:	1,000,000 cycles min.
Insulation Resistance:	100 MΩ min.
Dielectric Strength:	1000VAC for 60 +/- 5 sec
Housing:	UL 94V0 Thermoplastic
Contact Gap:	< 3mm (micro gap)



Ordering qty: 200pcs
Switch with lever: 1000pcs

Ordering Instructions

E81 A K - A A 01 Ag - 01

Types	Circuitry	Operating Force	Terminal Type	Lever Position	Lever Type	Contact Type	Versions
E81	A=SPDT	K	Ref. to table	A: standard position	01, 02, 03..99	Ag = silver	Standard: 01
E82	B=SPST-NC	L		B: high gear position	A1,A2 ..ZZ	Au = gold plated	Custom-made:
E83	C=SPST-NO	M		N: no lever		An = other spec.	02, 03, 04, ..99
		N			00: no lever	(n= 1, 2, 3..)	1A, 1B,1C ..1Y
		P					

Basic Switch Dimensions

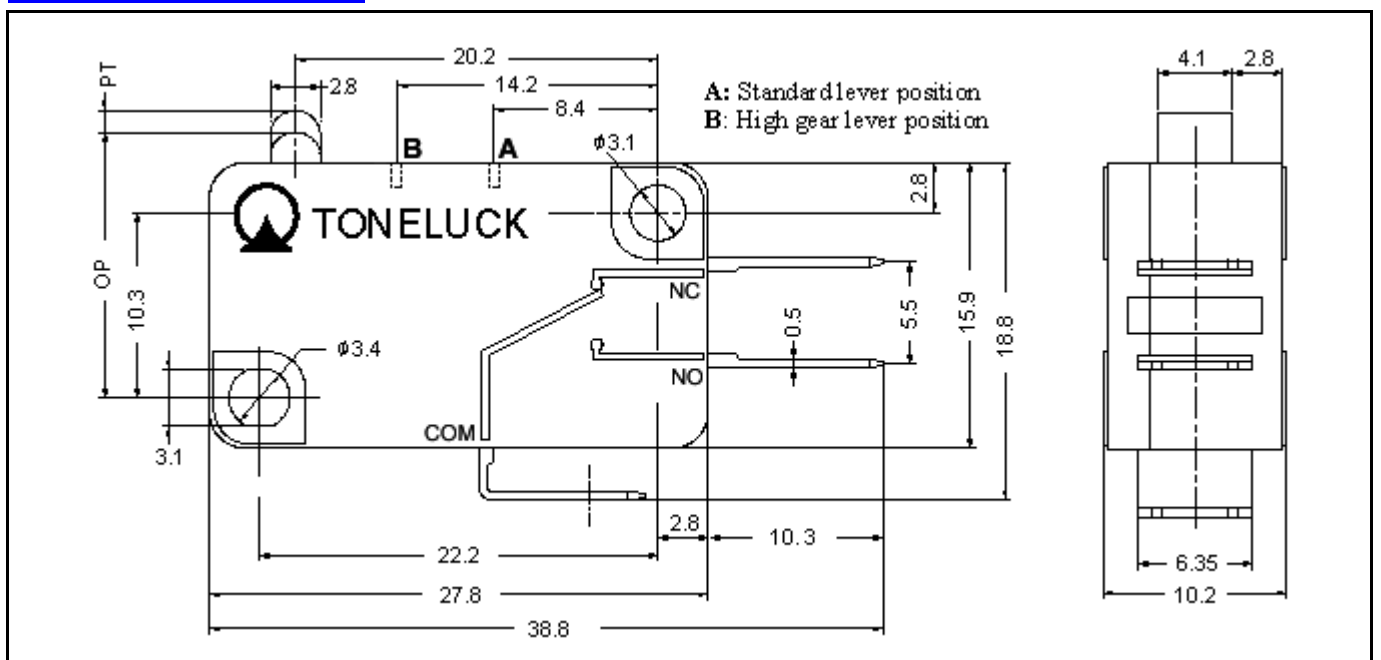

Standard Terminals

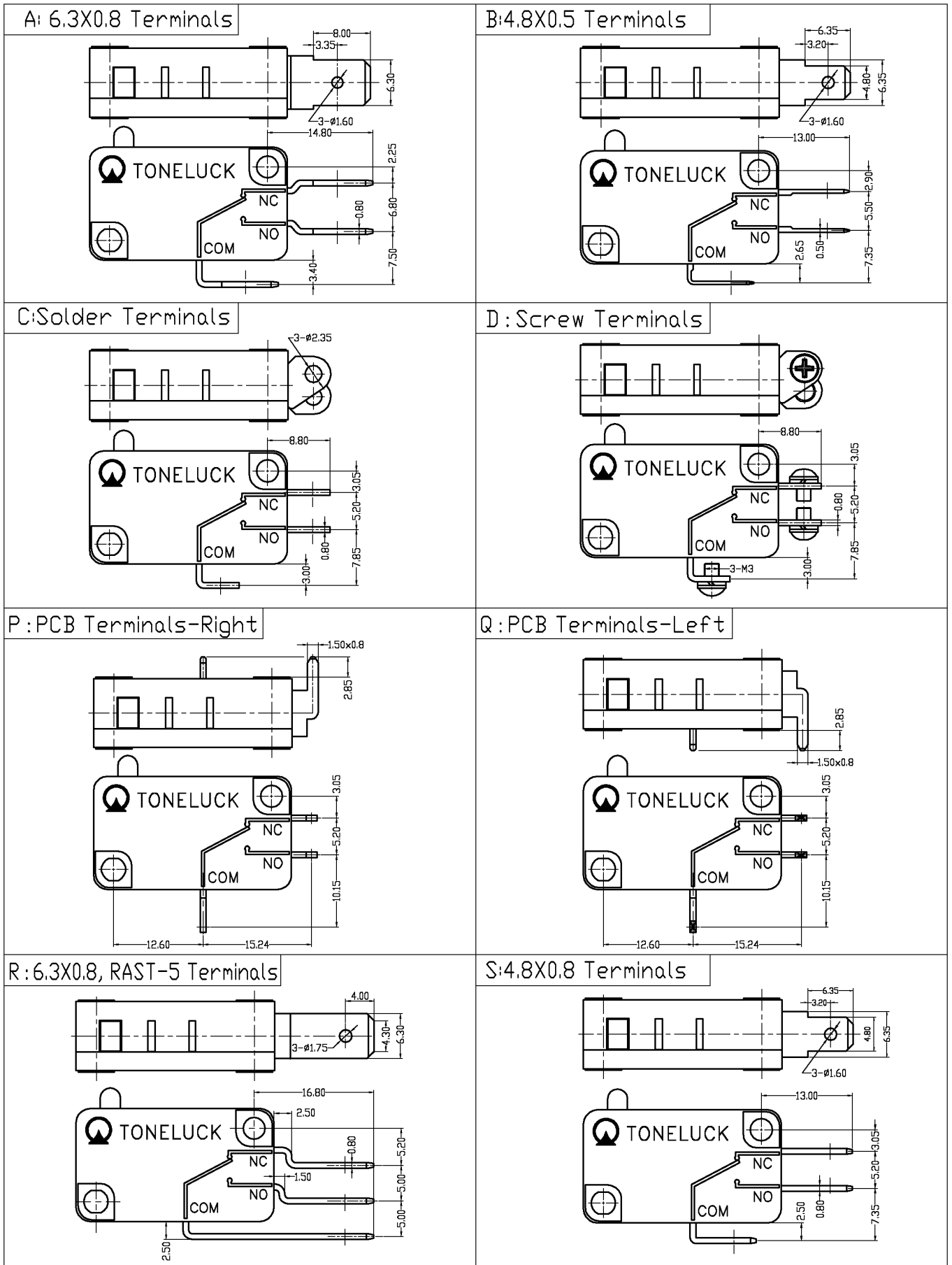

* Please refer to P.3 for standard levers and operation forces.

Specifications

L41	[25T85]:	0.1A 125/250VAC	100,000 cycles min.
L42	[25T85]:	5A 125/250VAC	100,000 cycles min.
L51	[25T125]:	0.1A 125/250VAC	100,000 cycles min.
L52	[25T125]:	5A 125/250VAC	100,000 cycles min.
L61	[25T150]:	0.1A 125/250	100,000 cycles min.
L62	[25T150]:	5A 125/250VAC	100,000 cycles min.
Mechanical Life:		1,000,000 cycles min.	
Insulation Resistance:		100 MΩ min.	
Dielectric Strength:		1000VAC for 60 +/- 5 sec	
Housing:		UL 94V0 Thermoplastic	
Contact Gap:		< 3mm	



Ordering qty: 200pcs
Switch with lever: 1000pcs

Ordering Instructions

L52 **A** **D** **-** **A** **A** **00** **Ag** **-** **01**

Series	Circuitry	Operating Force	Terminal Type	Lever Position	Lever Type	Contact Type	Versions
L41~L42	A=SPDT	D	Ref. to table	A: standard position	01, 02, 03..99	Ag = silver	Standard: 01
L51~L52	B=SPST-NC	F		B: high gear position	A1, A2..ZZ	Au = gold plated	Custom-made:
L61~L62	C=SPST-NO	G		N: no lever	00: no lever	An = other spec.	02, 03, 04, ...99
		H				(n= 1, 2, 3..)	

Basic Switch Dimensions

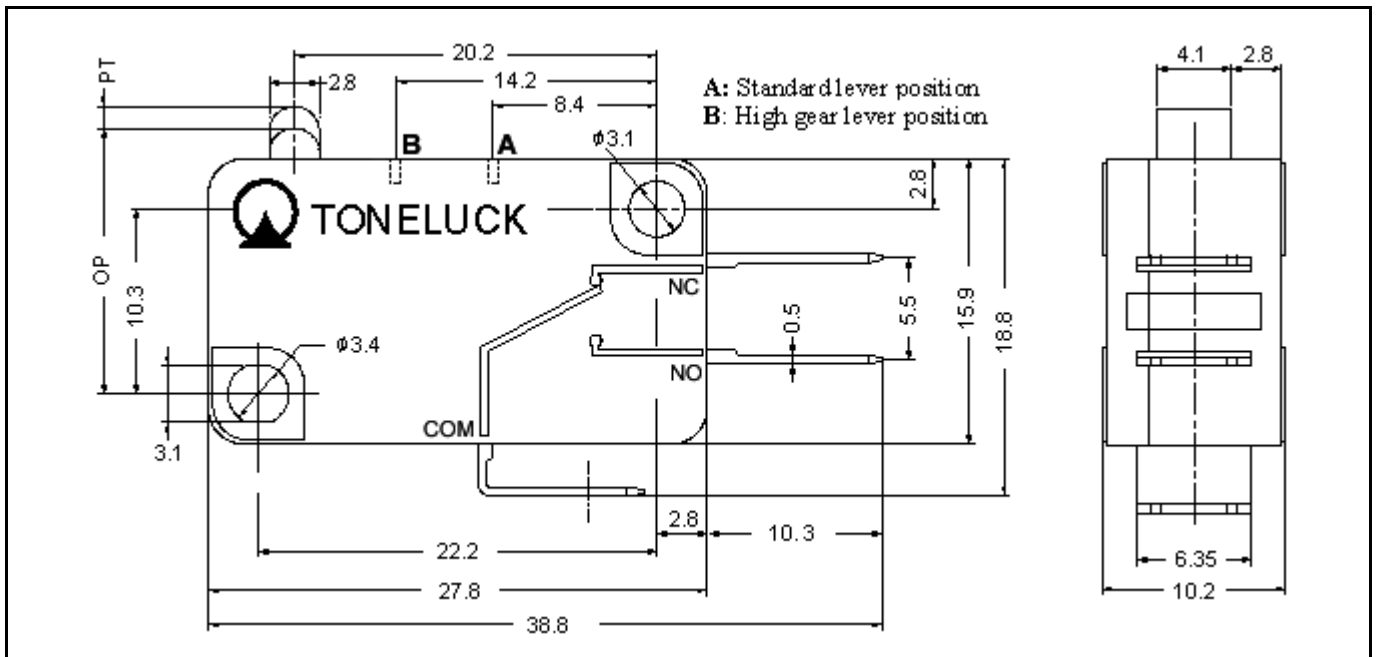

A: 6.3X0.8 Terminals

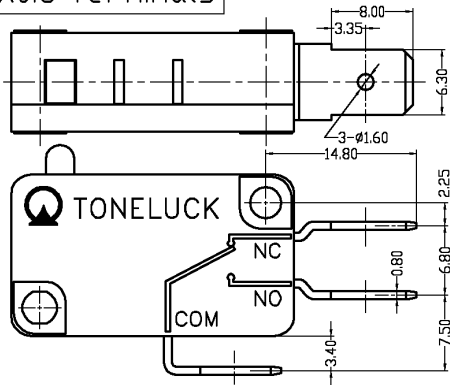

B: 4.8X0.5 Terminals

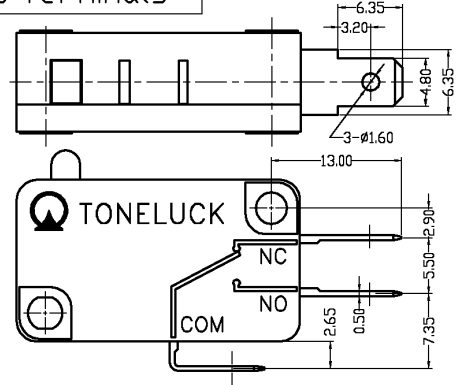

C: Solder Terminals

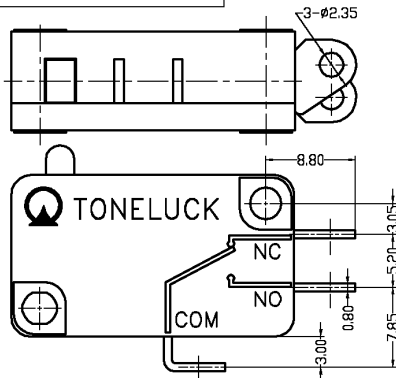

D: Screw Terminals

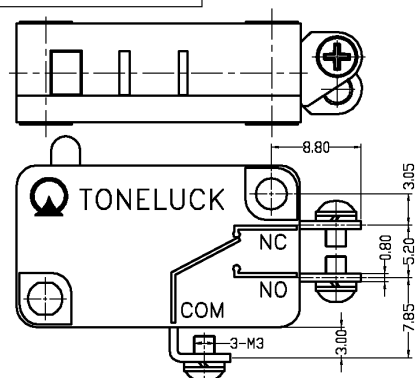

P: PCB Terminals-Right

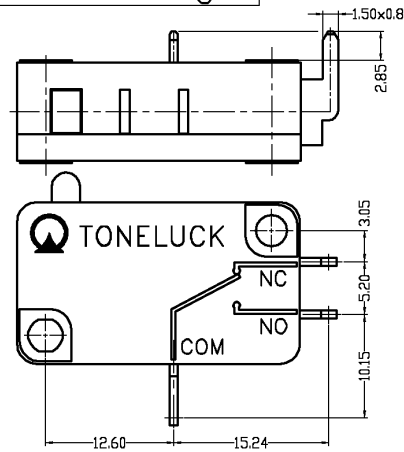

Q: PCB Terminals-Left

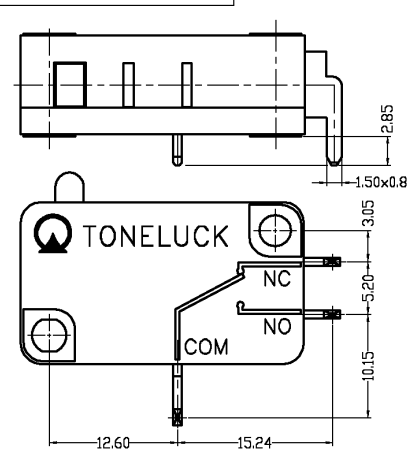

R: 6.3X0.8, RAST-5 Terminals

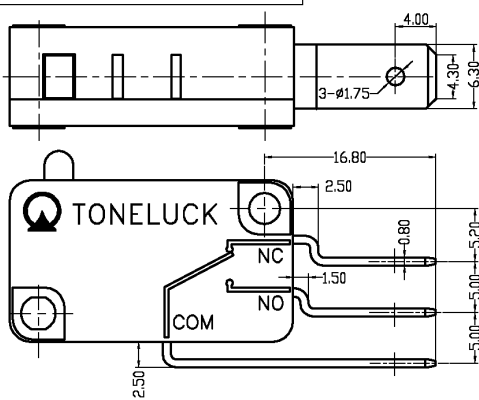

S: 4.8X0.8 Terminals

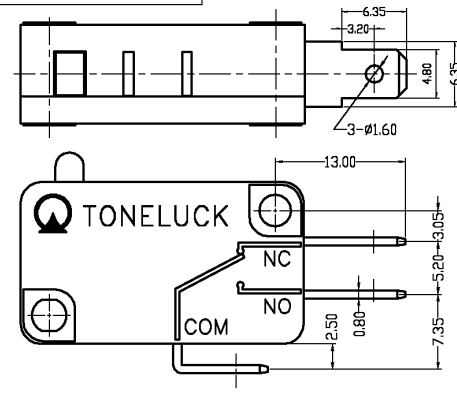

Standard Products

Series	Operating Temperature	Ratings	Operating force	Differential Movement	Differential Force
L41	25T85	0.1A 125/250VAC	D= 15gf max. F= 25gf max. G= 50gf max. H= 15gf max.	0.3mm max 0.3mm max 0.3mm max 0.15mm max	6gf max. 9gf max. 16gf max. 4gf max.
L42	25T85	5A 125/250VAC	D= 15gf max. F= 25gf max. G= 50gf max. H= 15gf max.	0.3mm max 0.3mm max 0.3mm max 0.15mm max	6gf max. 9gf max. 16gf max. 4gf max.
L51	25T125	0.1A 125/250VAC	D= 15gf max. F= 25gf max. G= 50gf max.	0.3mm max 0.3mm max 0.3mm max	6gf max. 9gf max. 16gf max.
L52	25T125	5A 125/250VAC	D= 15gf max. F= 25gf max. G= 50gf max.	0.3mm max 0.3mm max 0.3mm max	6gf max. 9gf max. 16gf max.
L61	25T150	0.1A 125/250VAC	D= 15gf max. F= 25gf max. G= 50gf max.	0.3mm max 0.3mm max 0.3mm max	6gf max. 9gf max. 16gf max.
L62	25T150	5A 125/250VAC	D= 15gf max. F= 25gf max. G= 50gf max.	0.3mm max 0.3mm max 0.3mm max	6gf max. 9gf max. 16gf max.

Special Characteristics:

Switches with operating force **H** is different from the others by their small Differential Movement and Differential Force:

$$\text{Differential Force} = \text{Operating Force} - \text{Release Force}$$

This switch is useful in control systems in which force measurement is extremely critical in the ON/OFF operations, a consistent and fixed operating point is required, sensitive and quick response to changes in force/pressure on the actuator.

Standard Products

Toneluck L-series micro is a highly sensitive device. If you need an external lever for your application, please let us know the details of your application and your drawing. Our factory will evaluate each case for you in terms of reliability and stability of the complete control system. Please contact Toneluck Sales Representatives for more details.

Specifications

Rating	16A(4) 125/250VAC (UL, VDE) 1/2HP 125VAC; 3/4HP 250VAC 0.4/125VDC; 0.2/250VDC 10.1A/125VAC (Tungsten)
Electrical Life Expectancy:	16A 125/250VAC > 50,000 cycles 10A 125/250VAC >100,000 cycles 3A 125/250VAC >200,000 cycles
Mechanical Life:	1,000,000 cycles min.
Operating Temp:	-25° C ~ +85° C (MQS-216S) -25° C ~ +125° C (MQS-216T)
Insulation Resistance:	100 MΩ min.
Dielectric Strength:	1000VAC for 60 +/- 5 sec
Housing:	UL 94V0 Thermoplastic



Ordering qty: 200pcs
Switch with lever: 1000pcs

Ordering Instructions

MQS-216S	A	01	A	A	K	01
-----------------	----------	-----------	----------	----------	----------	-----------

T85: MQS-216S	Lever Position	Lever Type	Terminal Type	Circuitry	Operating Force	Versions
T125:MQS-216T	A	01, 02, 03..99	Ref. to drawing	(silver contacts) A=SPDT B=SPST -NC C=SPST -NO	K L M N P	Standard: 01 Custom-made: 02, 03, 04, ...99 1A, 1B,1C ..1Y
	B	A1, A2,A3..ZZ				
	N=no lever	00=no lever		(Gold Contacts) D=SPDT E=SPST-NC F=SPST -NO		

Basic Switch Dimensions

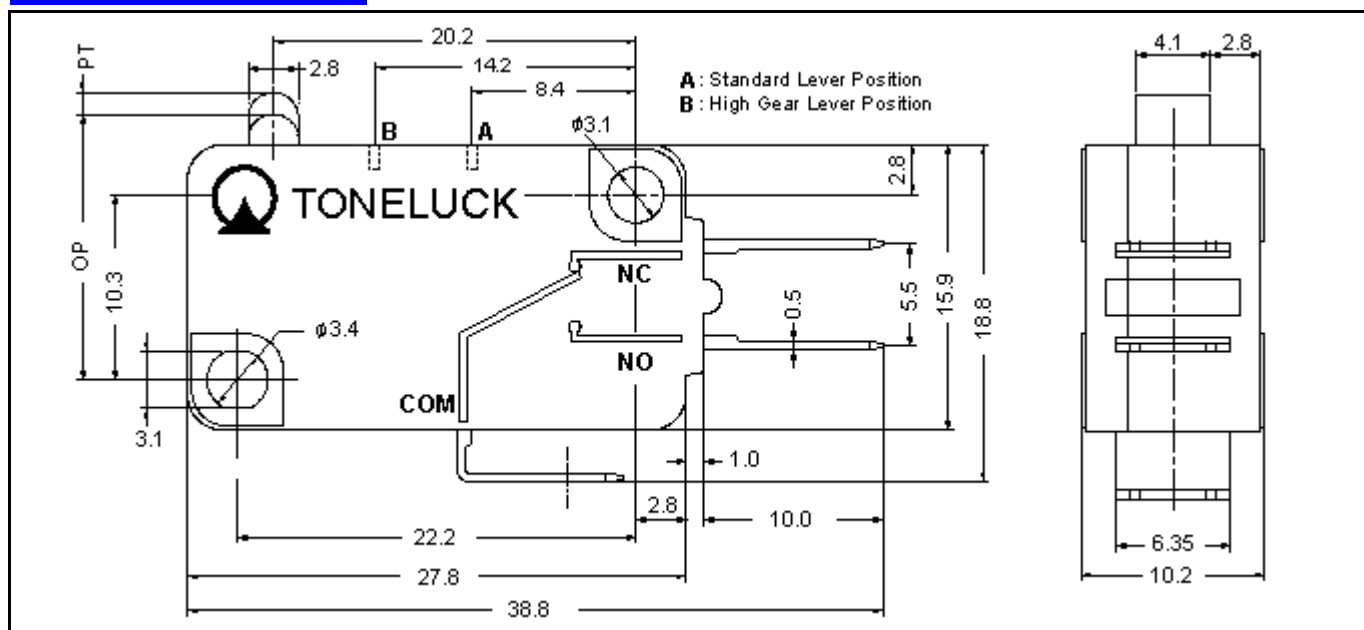

Standard Terminals

A: 6.3x0.8 terminals

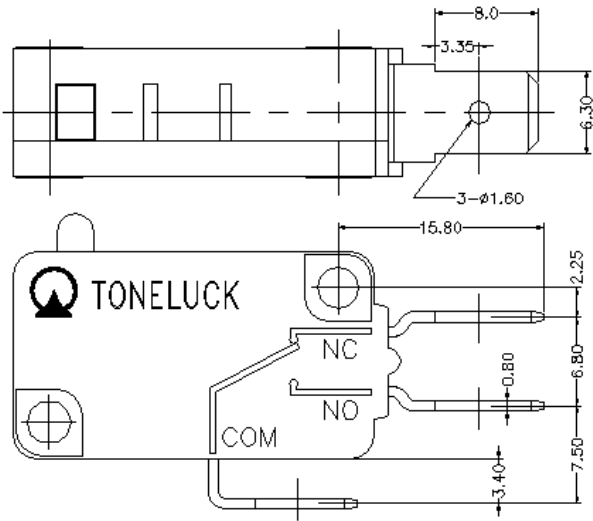

J: 6.3x0.8 terminals

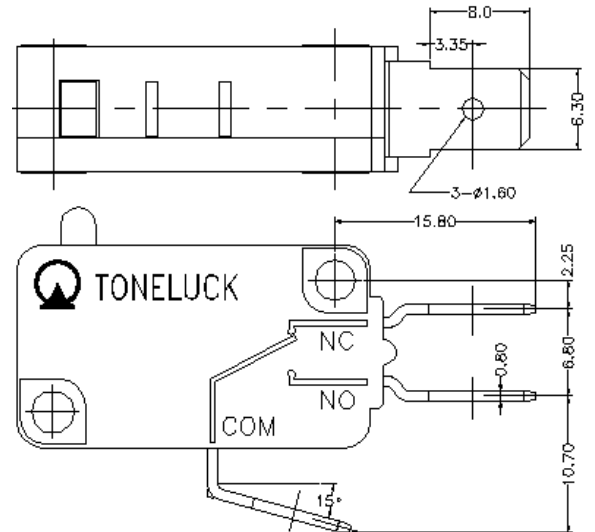

K: 6.3x0.8 terminals

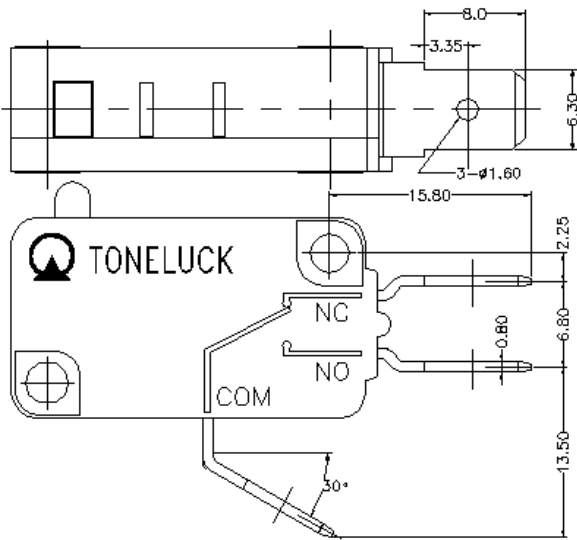

B: 4.8x0.5 terminals

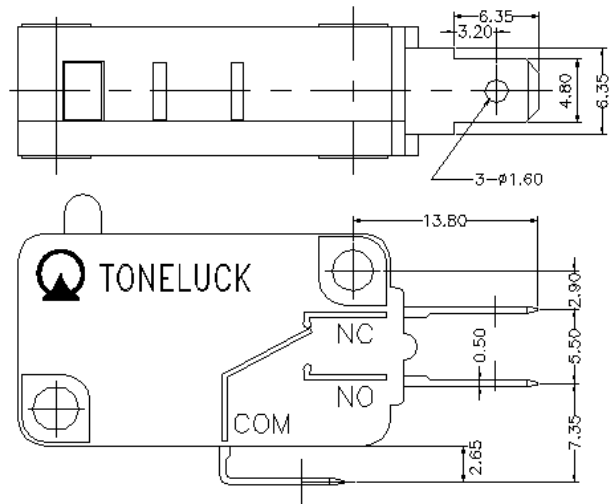

H: 4.8x0.5 terminals

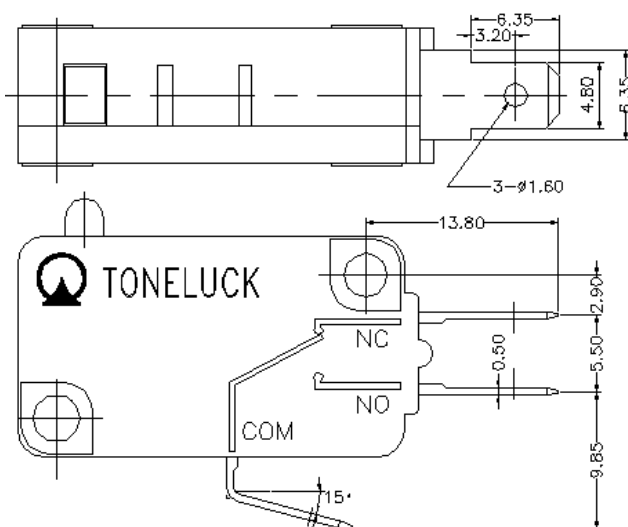

M: 4.8x0.5 terminals

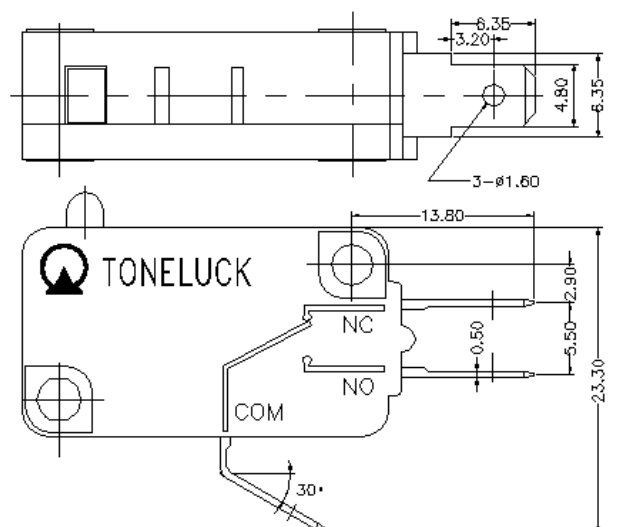

S: 4.8x0.8 terminals

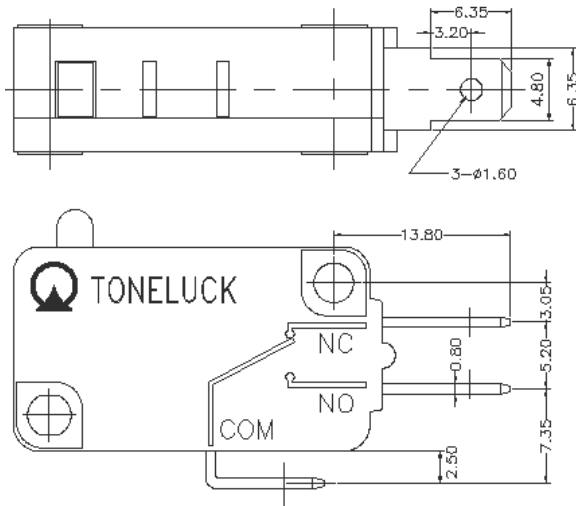

T: 4.8x0.5 terminals

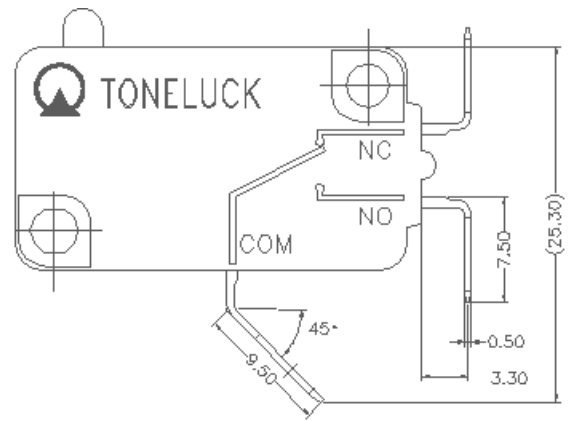

C: Solder Terminals

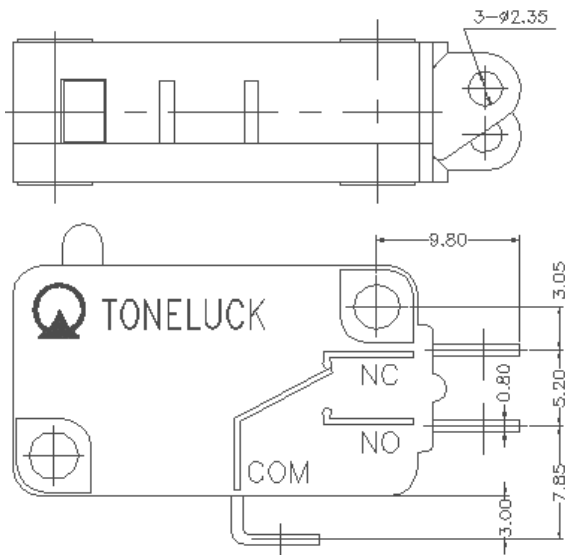

D: Screw Terminals

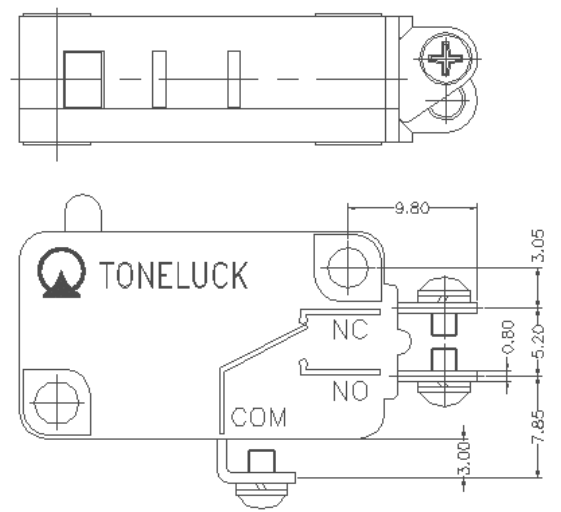

P: PCB Terminal -Right

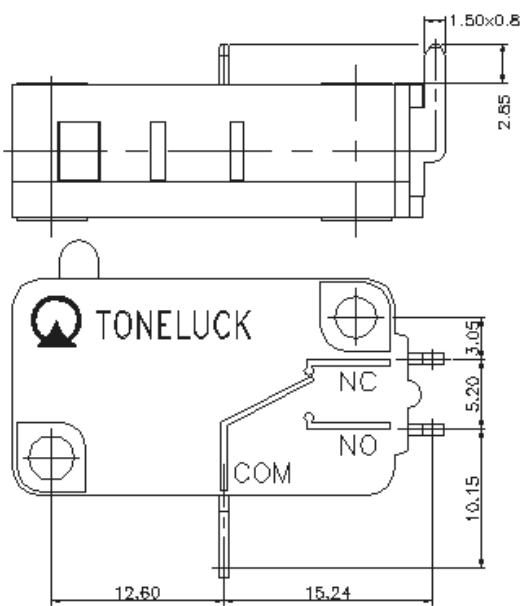

Q: PCB Terminal -Left

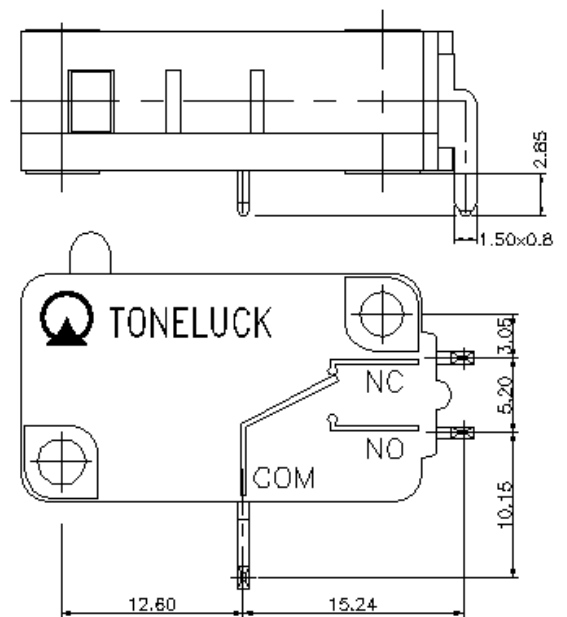

U: Ultra Short Solder Terminals

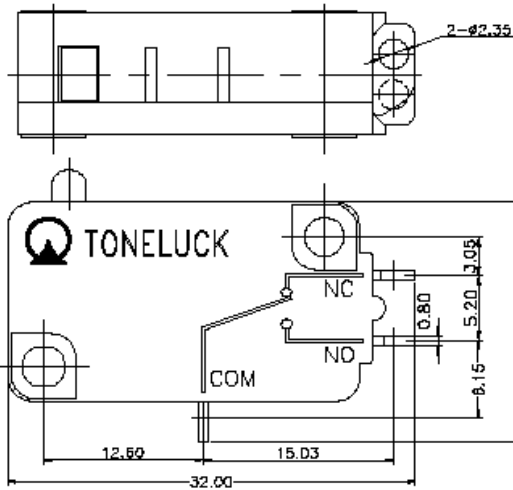

V: Bent Ultra Short Solder Terminals

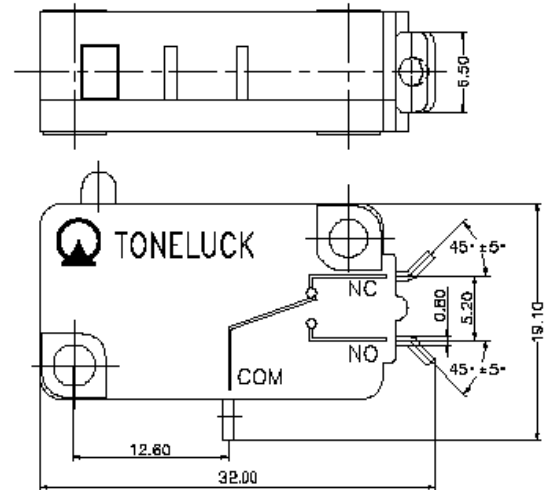

R: 6.3x0.8, RAST-5 terminals

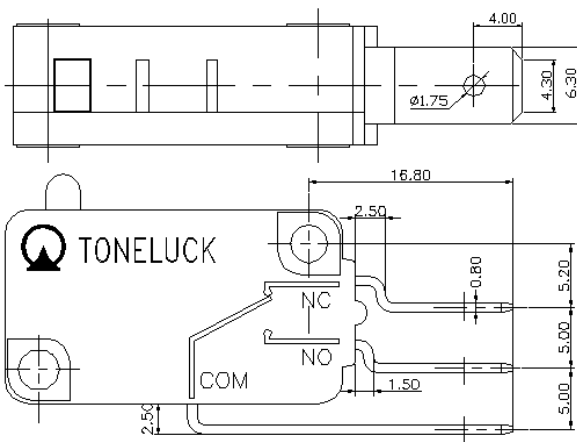

Lever Positions

A= standard position

B= high ratio position

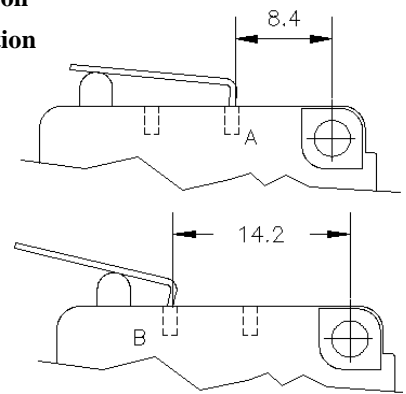

** Please refer to P.3 for standard levers and operation forces.*

Specifications

MQS-210H:	10A 125/250VAC > 100,000 cycles 1/2HP 125/250VAC 1A 30VDC
Electrical Life	100,000 cycles min.
Mechanical Life:	1,000,000 cycles min.
Operating Temp:	-40° C ~ +150° C
Insulation Resistance:	100 MΩ min.
Dielectric Strength:	1000VAC for 60 +/- 5 sec
Housing:	UL 94V0 Thermoplastic
Operating Force:	55 +/- 15gf, 100 +/- 25gf 160 +/- 30gf, 200 +/- 30gf 350 +/- 50gf



Ordering qty: 200pcs
Switch with lever:1000pcs

Ordering Instructions

MQS-210H	A	01	A	A	K	01
MQS-210H	<u>Lever Position</u>	<u>Lever Type</u>	<u>Terminal Type</u>	<u>Circuitry</u>	<u>Operating Force</u>	<u>Versions</u>
	A	01, 02 ..99	Ref. to drawing	(silver contacts) A=SPDT B=SPST -NC C=SPST -NO	K L M N P	Standard: 01 Custom-made: 02, 03, 04, ...99 1A, 1B,1C ..1Y
	B	A1, A2..ZZ				
	N=no lever	00=no lever		(Gold Contacts) D=SPDT E=SPST-NC F=SPST -NO		

Basic Dimensions

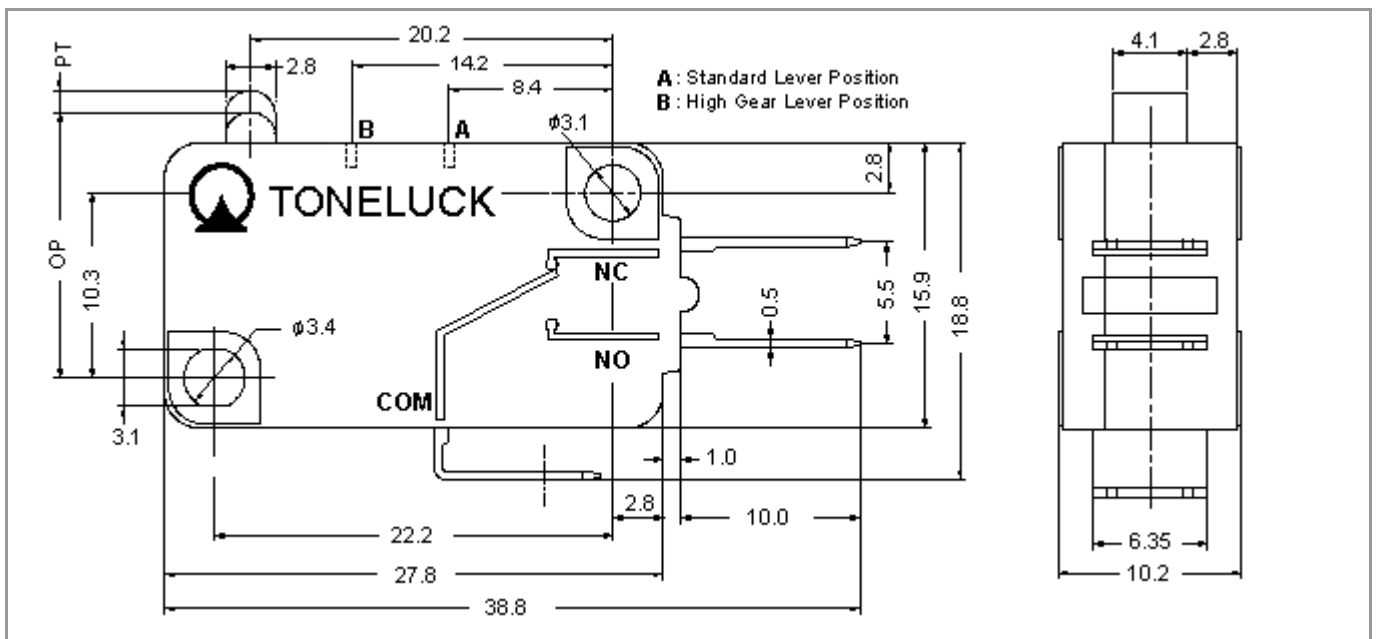

Standard Terminals

A: 6.3x0.8 terminals

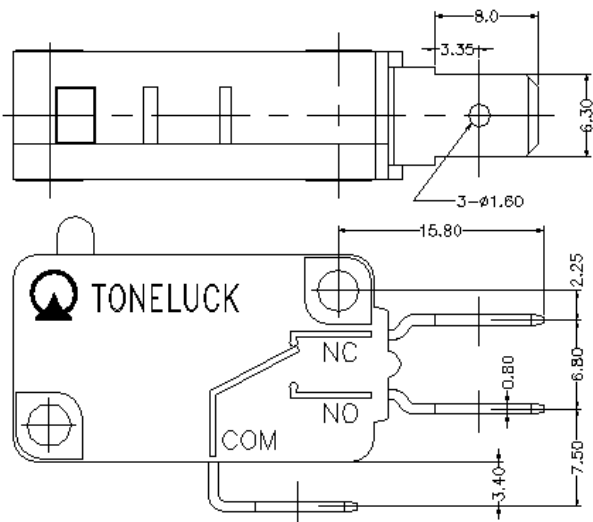

J: 6.3x0.8 terminals

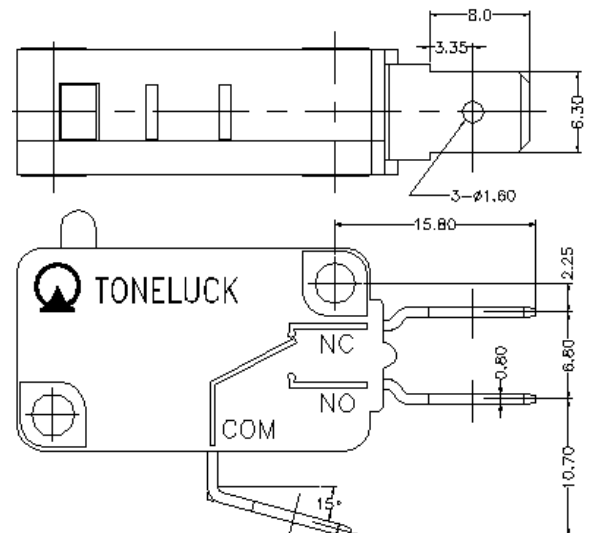

K: 6.3x0.8 terminals

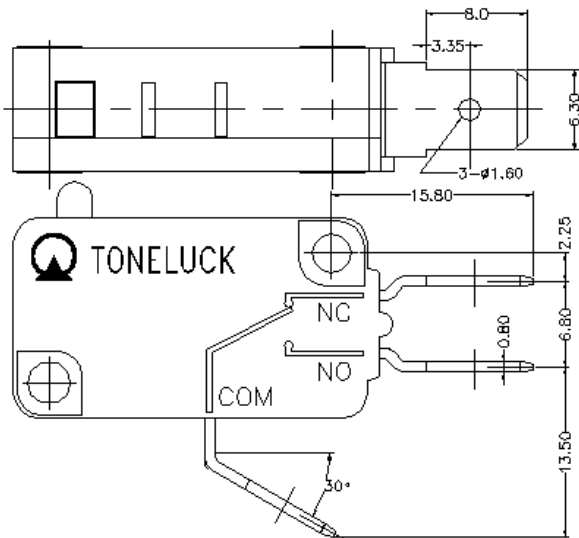

B: 4.8x0.5 terminals

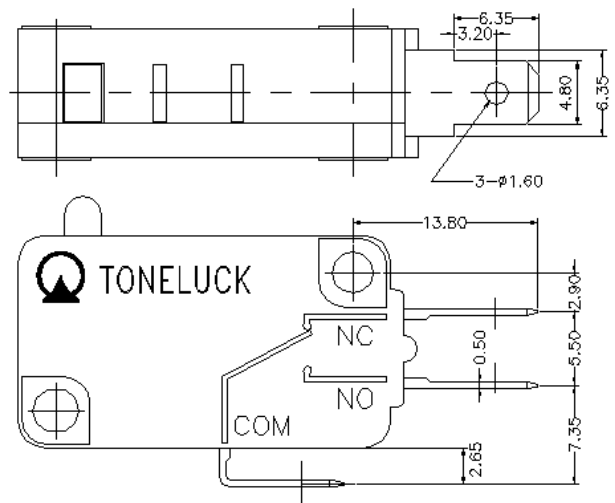

H: 4.8x0.5 terminals

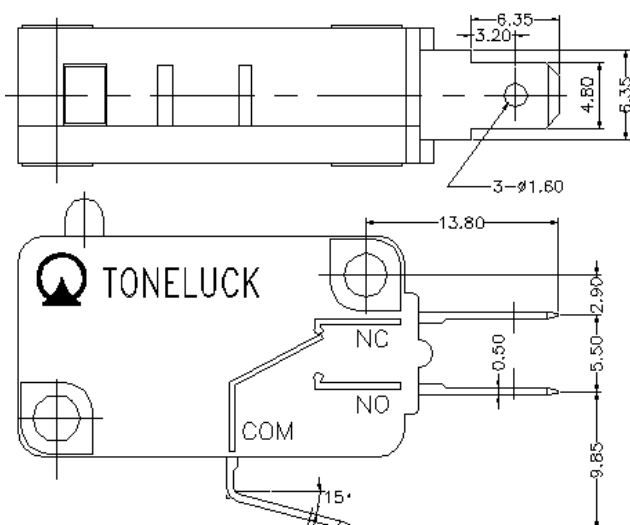

M: 4.8x0.5 terminals

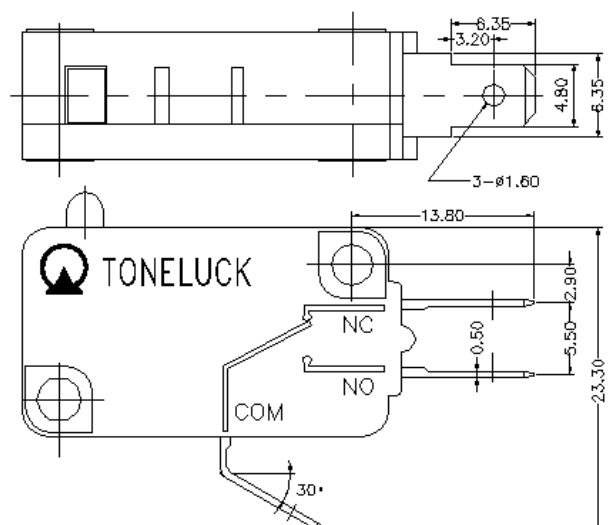

S: 4.8x0.8 terminals

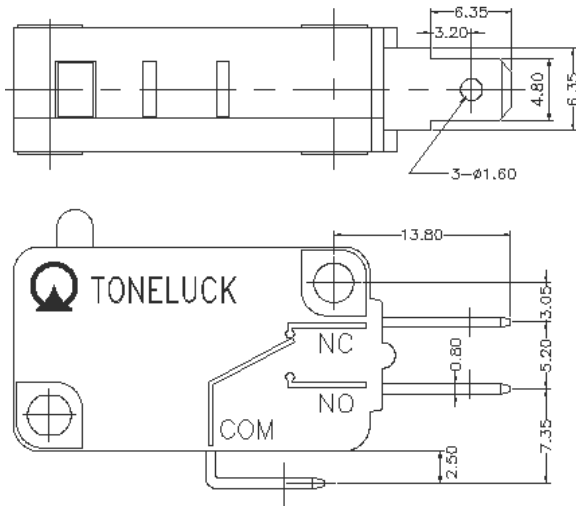

T: 4.8x0.5 terminals

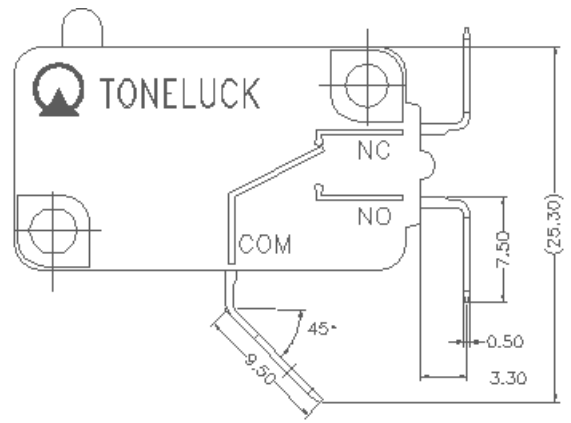

C: Solder Terminals

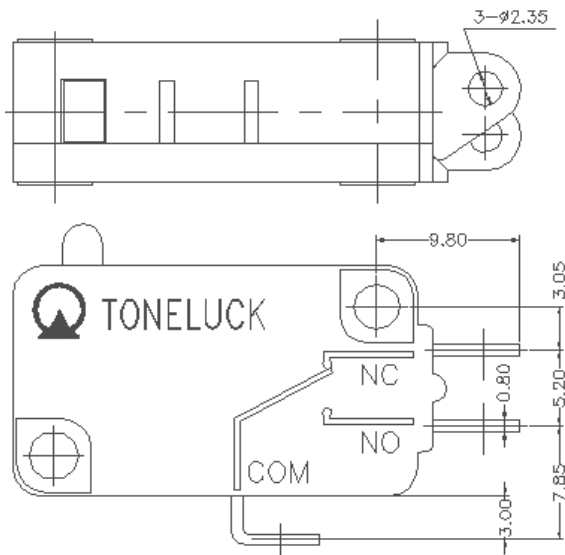

D: Screw Terminals

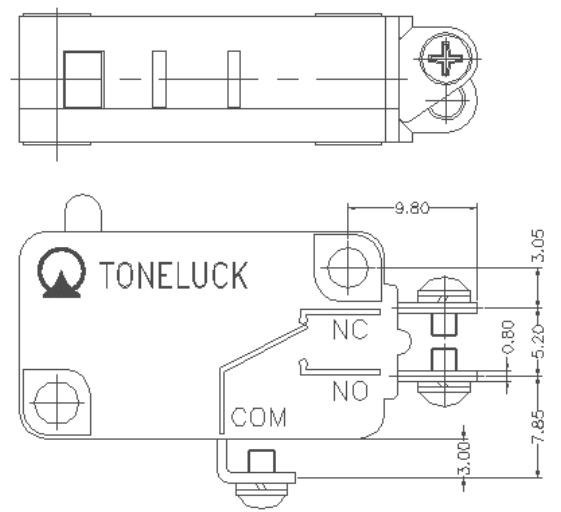

P: PCB Terminal -Right

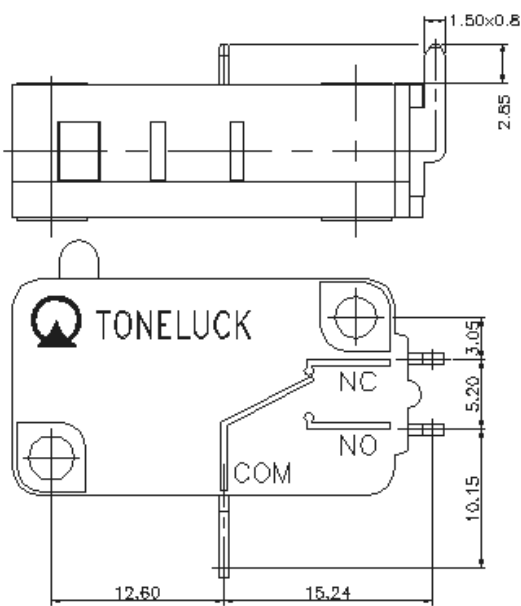

Q: PCB Terminal -Left

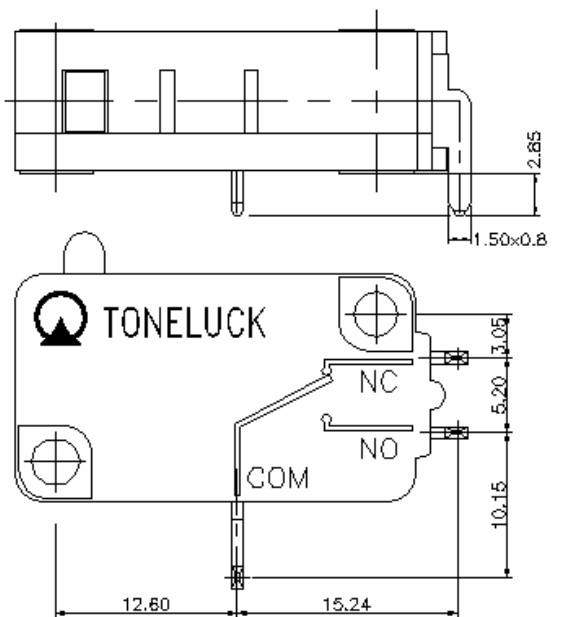

U: Ultra Short Solder Terminals

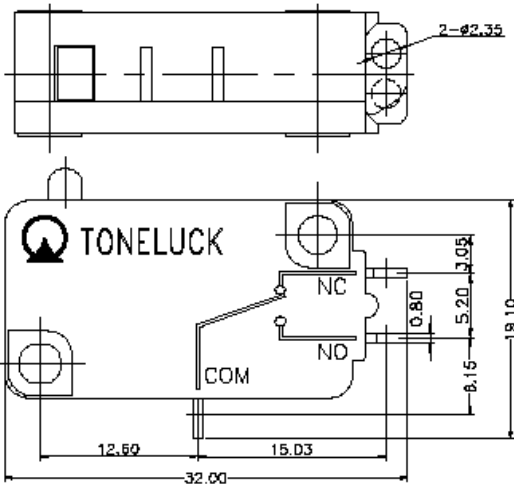

V: Bent Ultra Short Solder Terminals

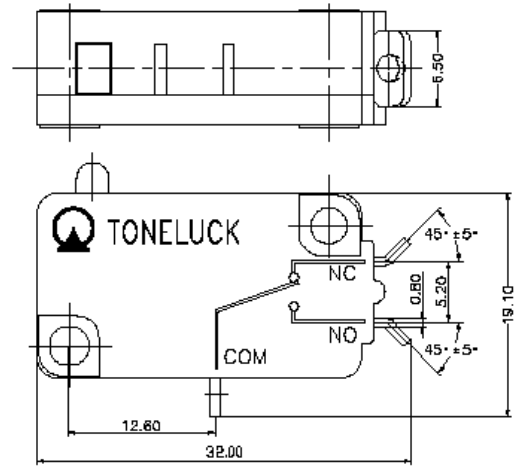

R: 6.3x0.8, RAST-5 terminals

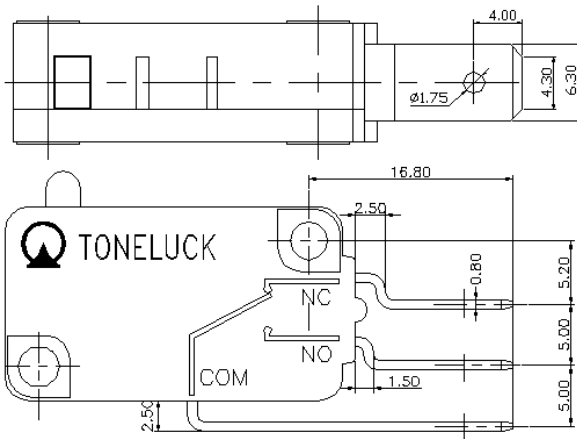

Lever Positions

A= standard position
B= high ratio position

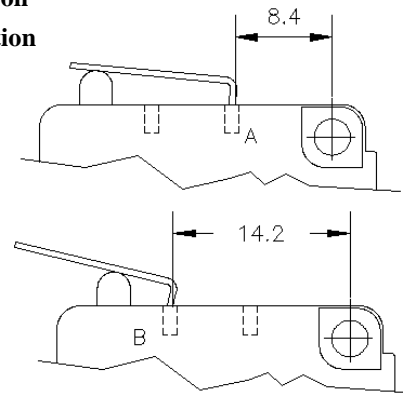

** Please refer to P.3 for standard levers and operation forces.*

THK-2 Quick Action Leaf Switch

Specifications

Rating:	0.2A 60VDC
Electrical Life:	50,000 cycles min.
Mechanical Life:	50,000 cycles min.
Operating Temp:	-10° C ~ +60° C
Contact Resistance:	100mΩ max. initial
Insulation Resistance:	100 MΩ min.
Dielectric Strength:	500VAC for 60 +/- 5 sec
Contacts:	Silver plated
Operating Force:	80gf max.

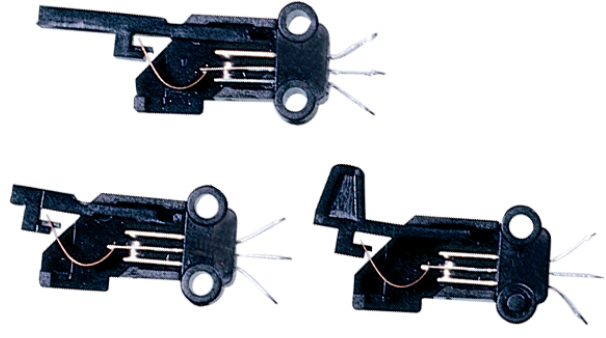

Ordering qty: 200pcs

Dimensions

THK-2A-0001

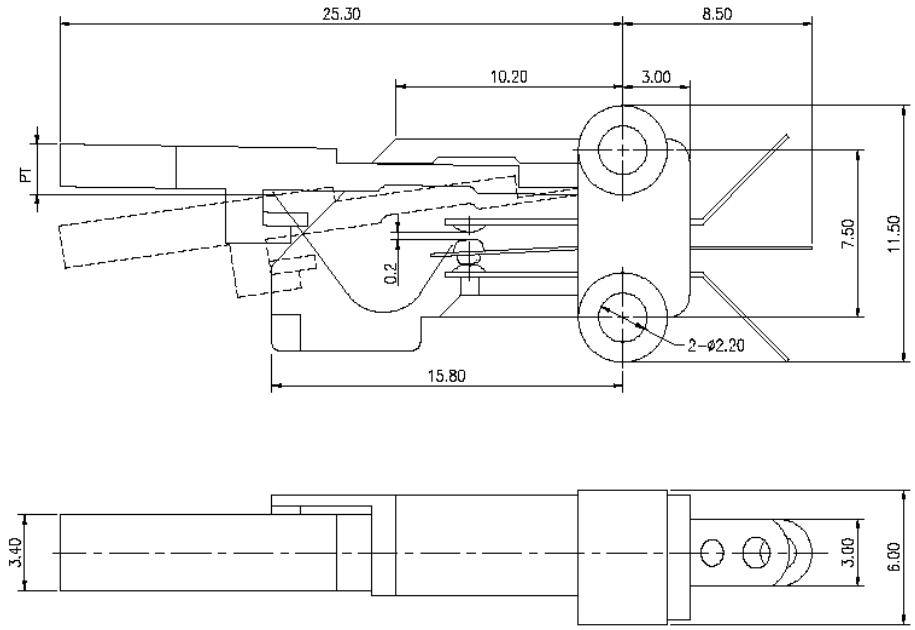

THK-2B-0002

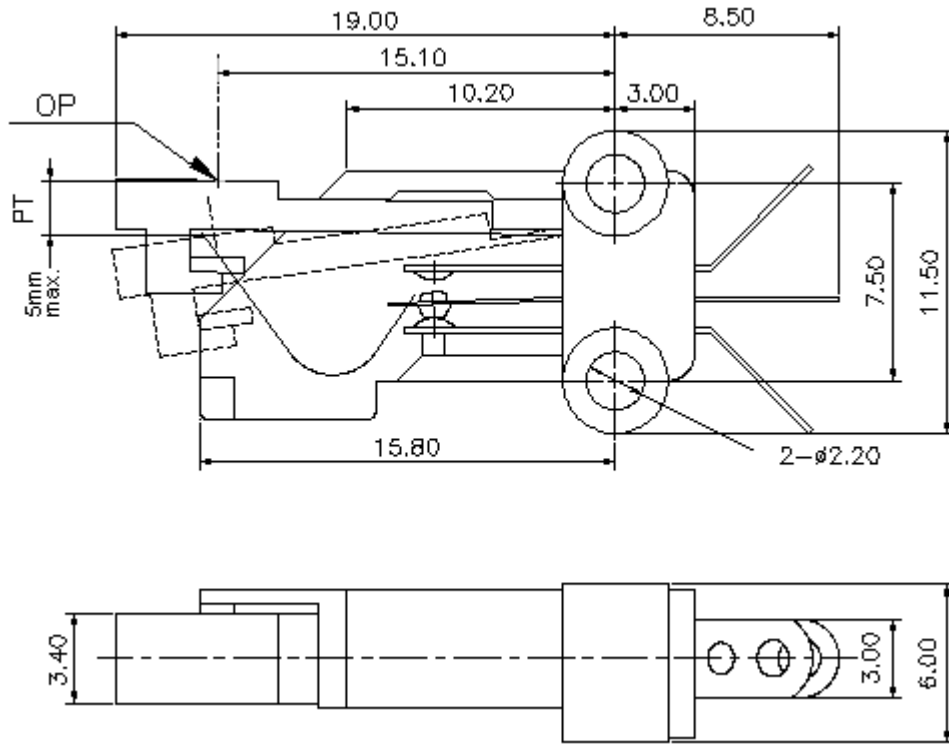

THK-2C-0003

